

PRODUCT DATA SHEET

PRODUCT CODE: DYK501

DESCRIPTION: PP-IML Container for Food Packaging



TECHNICAL DRAWINGS & PICTURES

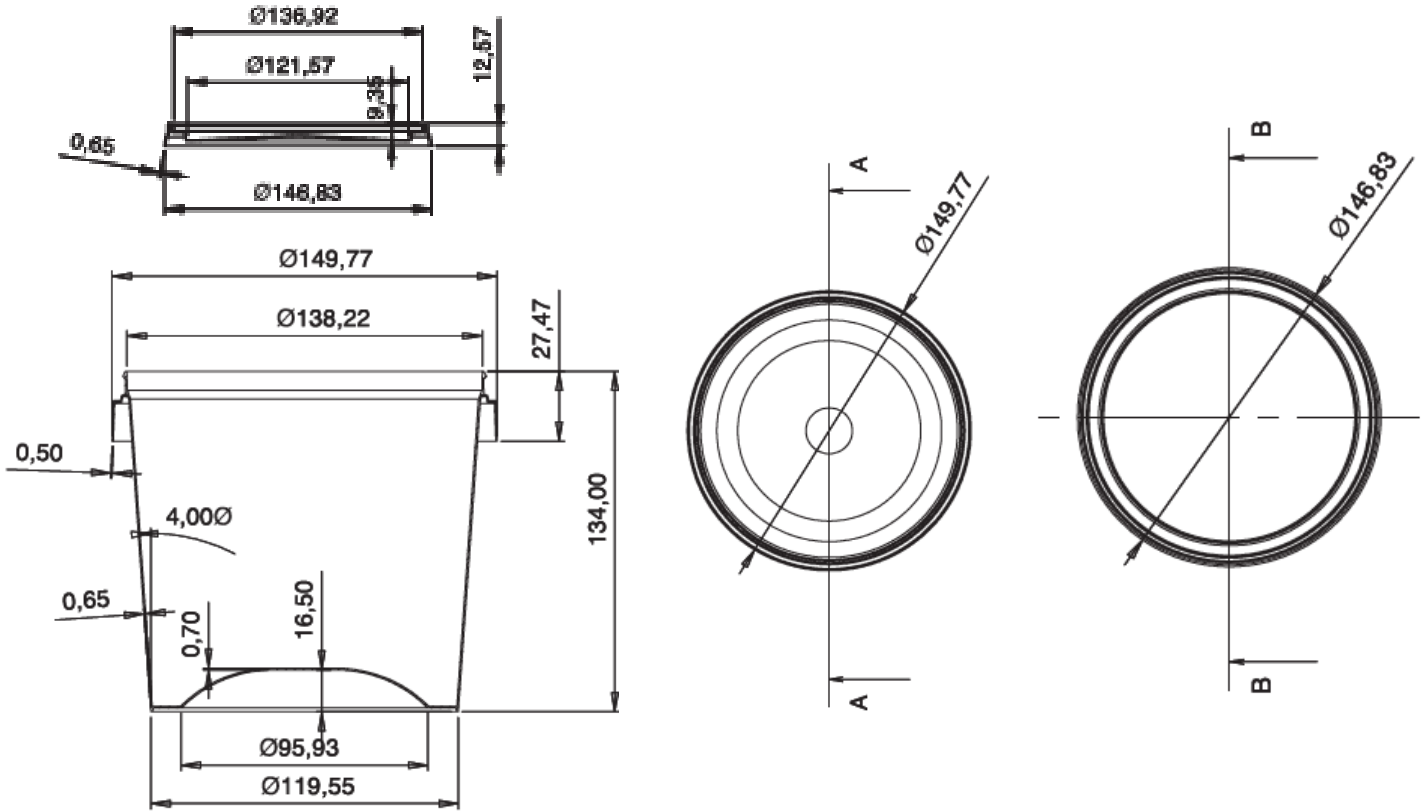

MATERIAL, COLOR, QUALITY CONTROL and WEIGHT

Containers and lids are produced by polypropylene in grades approved for food packaging according to New Code for Foodstuff and beverages 1998, Chapter II, Art.26.
Both lid and the container are food grade for human consumption.

100%
 Recyclable
 PP Material



DYK501 container and lid can be produced with all colors as per the demand of the customer.
 Production is certificated according to EN ISO 9001:2000.



Container: 23,5 gr (±2%) Lid: 6,75 gr (±2%) Volume: 500 ml

LOGISTIC & PALLETISING

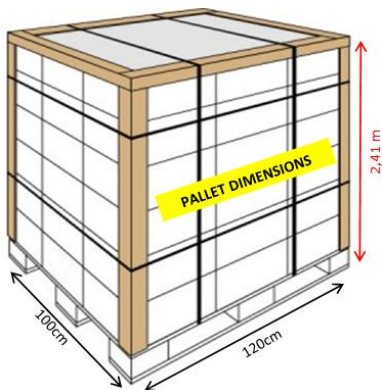

Quantity per Pallet	:	10.800 pieces	(Tub)
Quantity per Pallet	:	43.200 pieces	(Lid)
Quantity per Truck	:	253.440 sets	(Set = Body + Lid)
Quantity per 40'HC Container	:	207.360 sets	(Set = Body + Lid)
Quantity per 20'DC Container	:	69.120 sets	(Set = Body + Lid)

