

PRODUCT DATA SHEET

PRODUCT CODE: DYF380

DESCRIPTION: PP-IML Container for Food Packaging

$$\sum_{i=1}^{\infty} P_i$$

DivanPackaging

www.divanpackaging.com

TECHNICAL DRAWINGS & PICTURES

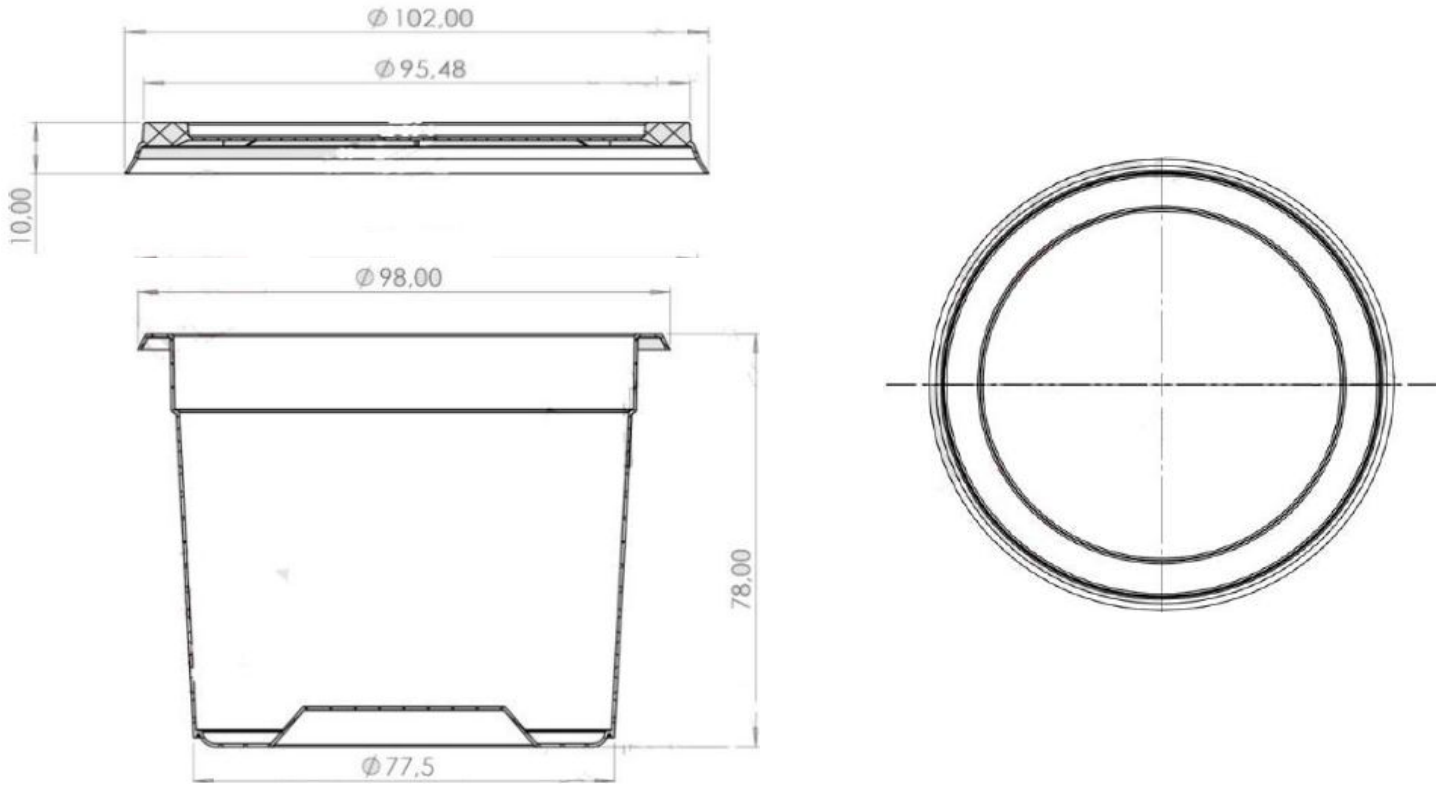

MATERIAL, COLOR, QUALITY CONTROL and WEIGHT

Containers and lids are produced by polypropylene in grades approved for food packaging according to New Code for Foodstuff and beverages 1998, Chapter II, Art.26.

Both lid and the container are food grade for human consumption.

DYF380 container and lid can be produced with all colors as per the demand of the customer.

Production is certificated according to EN ISO 9001:2000.

Container: 16 gr (±%5)

Lid: 6 gr (±%5)

Volume: 380 ml

100%
Recyclable
PP Material



LOGISTIC & PALLETISING

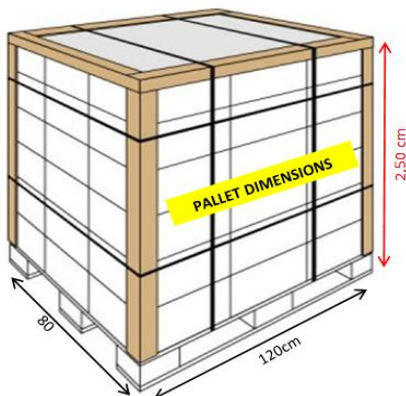

Quantity per Pallet	:	10.800 pieces	(Tub)
Quantity per Pallet	:	31.360 pieces	(Lid)
Quantity per Truck	:	331.375 sets	(Set = Body + Lid)
Quantity per 40'HC Container	:	241.000 sets	(Set = Body + Lid)
Quantity per 20'DC Container	:	88.350 sets	(Set = Body + Lid)

