

PRODUCT DATA SHEET

PRODUCT CODE: DKK100

DESCRIPTION: PP-IML Container for Food Packaging



TECHNICAL DRAWINGS & PICTURES

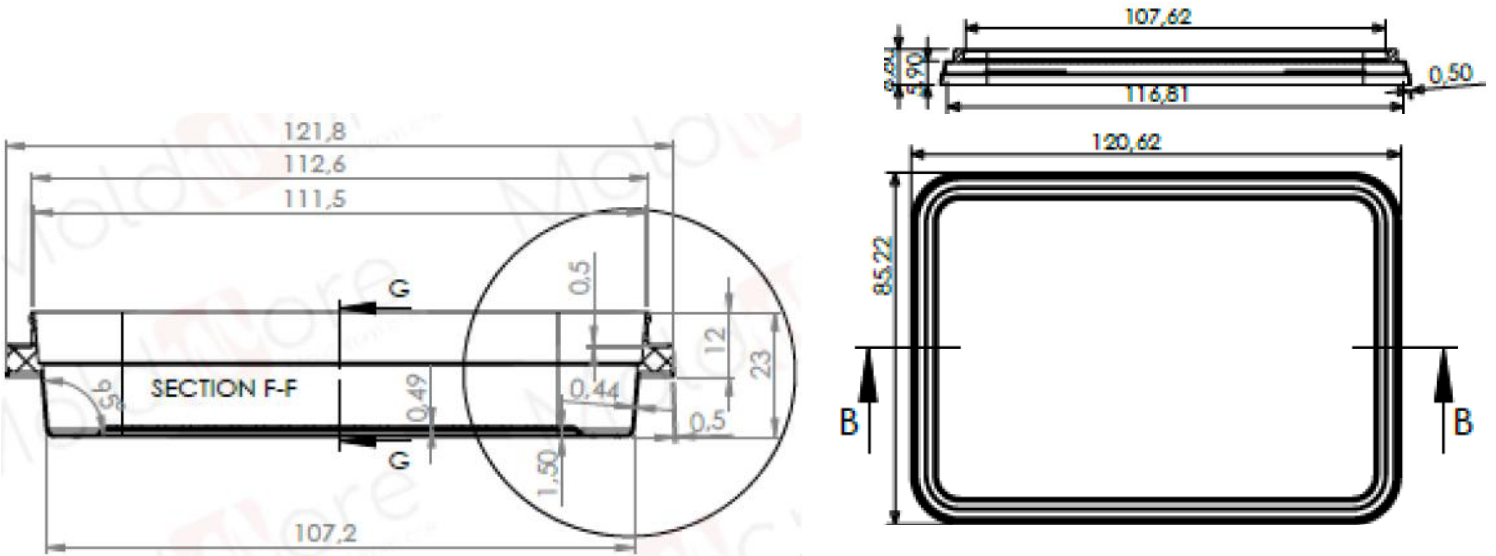

MATERIAL, COLOR, QUALITY CONTROL and WEIGHT

Containers and lids are produced by polypropylene in grades approved for food packaging according to New Code for Foodstuff and beverages 1998, Chapter II, Art.26.

Both lid and the container are food grade for human consumption.

100%
Recyclable
PP Material



DKK100 container and lid can be produced with all colors as per the demand of the customer.

Production is certificated according to EN ISO 9001:2000.

Container: 10,5 gr (±%5)

Lid: 6,5 gr (±%5)

Volume: 100 ml

LOGISTIC & PALLETISING

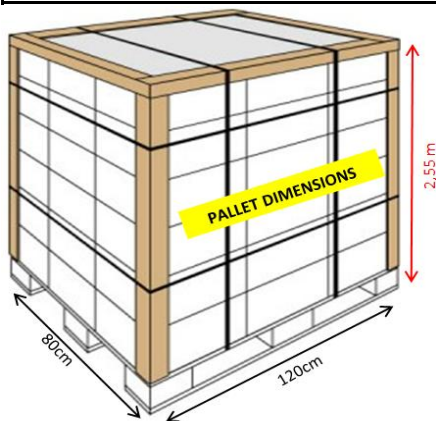

Quantity per Pallet	:	15.600 pieces	(Tub)
Quantity per Pallet	:	39.000 pieces	(Lid)
Quantity per Truck	:	367.700 sets	(Set = Body + Lid)
Quantity per 40'HC Container	:	267.400 sets	(Set = Body + Lid)
Quantity per 20'DC Container	:	98.050 sets	(Set = Body + Lid)

