

PRODUCT DATA SHEET

PRODUCT CODE: DKK1065

DESCRIPTION: 1L PP-IML Container for Food Packaging



TECHNICAL DRAWINGS & PICTURES

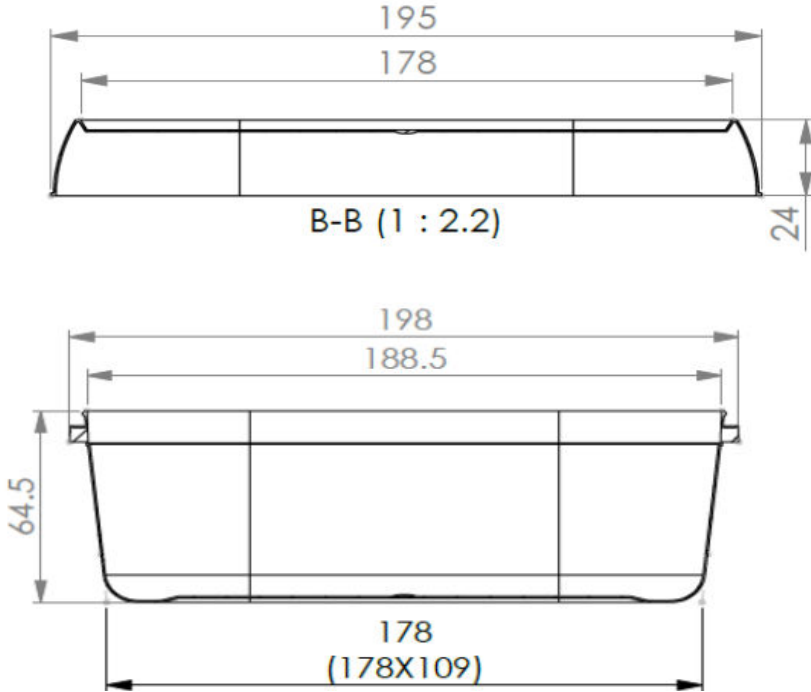

MATERIAL, COLOR, QUALITY CONTROL and WEIGHT

Containers and lids are produced by polypropylene in grades approved for food packaging according to New Code for Foodstuff and beverages 1998, Chapter II, Art.26.
Both lid and the bucket are food grade for human consumption.

DYK1065 container and lid can be produced with all colors as per the demand of the customer.
 Production is certificated according to EN ISO 9001:2000.
 Container: 41gr (±5%) Lid: 13gr (±5%) Volume: 1000 ml

**100%
 Recyclable
 PP Material**



LOGISTIC & PALLETISING

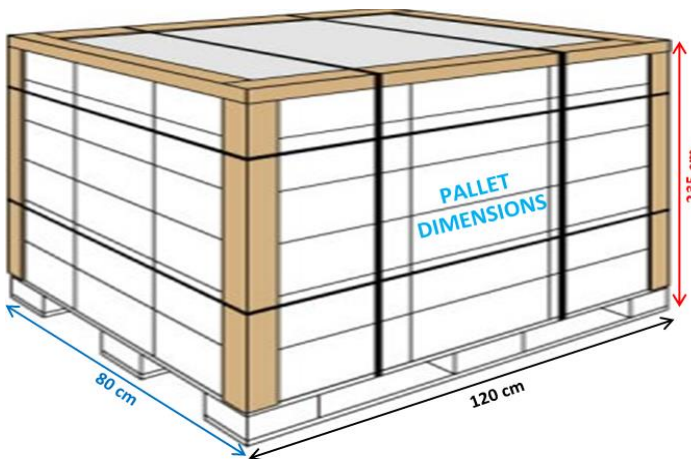

Carton Box Dimensions (Tube)	:	40*60*44 (w*l*h)(cm)
Quantity / Carton Box (Tube)	:	333 pcs
Carton Box Dimensions (Lid)	:	40*60*44 (w*l*h)(cm)
Quantity / Carton Box (Lid)	:	360 pcs
Carton Boxes / Pallet	:	20 pcs
Quantity / Pallet (Tube)	:	6.660 pcs
Quantity / Pallet (Lid)	:	7.200 pcs
Quantity / Standart Truck	:	113.550 pcs (sets)
Quantity / 20'DC Container	:	37.850 pcs (sets)
Quantity / 40'HC Container	:	82.580 pcs (sets)

please ask for the quantites loaded without pallets.

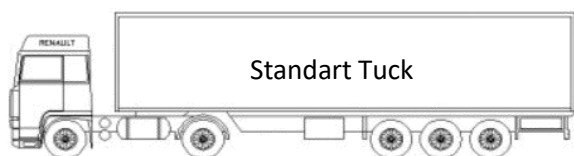

20'DC Container

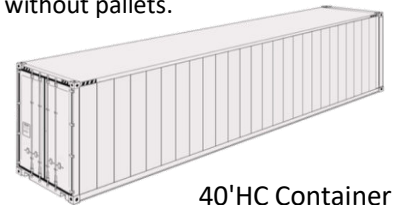

40'HC Container