

# PRODUCT DATA SHEET

$$\sum_{i=1}^{\infty} P_i$$

**DivanPackaging**

www.divanpackaging.com

PRODUCT CODE: D400

DESCRIPTION: PP-IML Tub with Lid

## TECHNICAL DRAWINGS & PICTURES

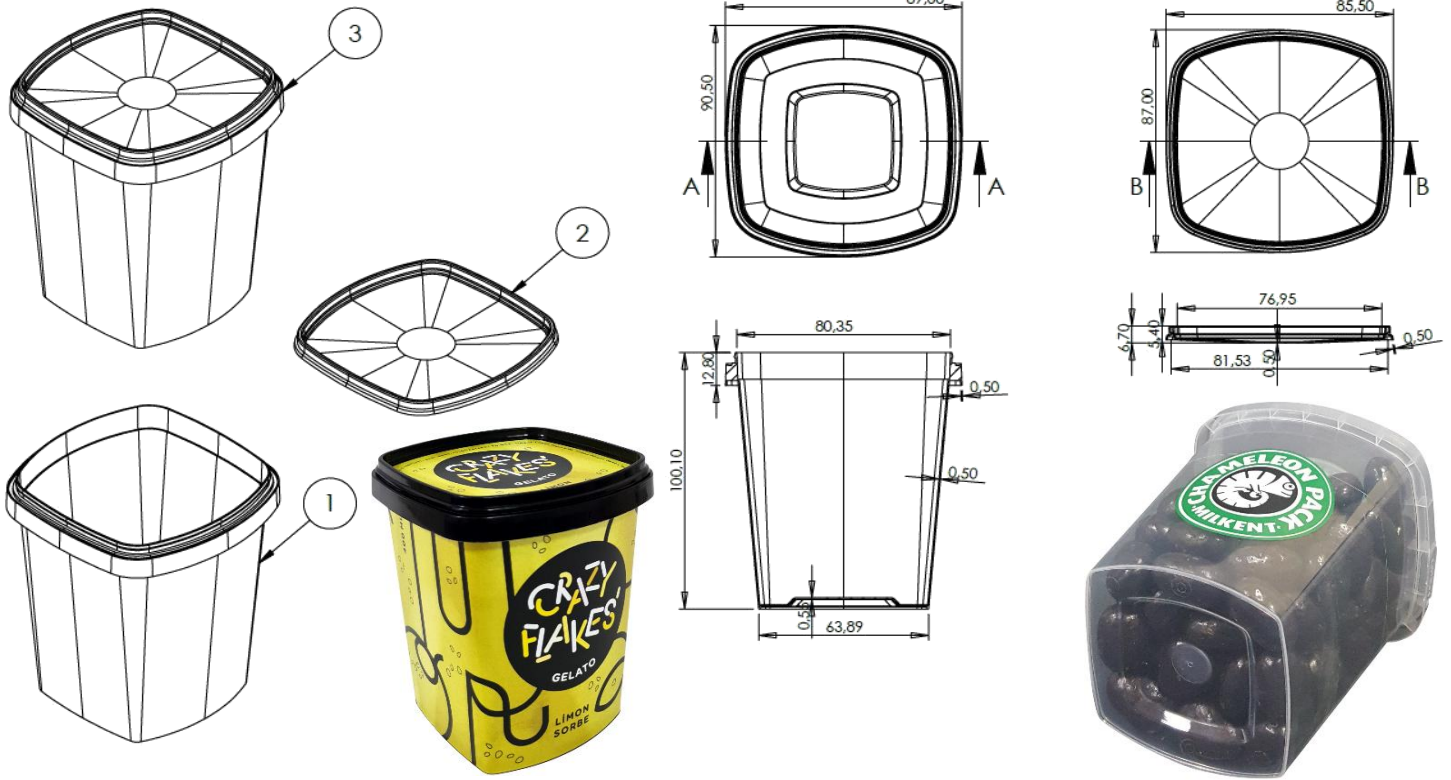

## MATERIAL, COLOR, QUALITY CONTROL and WEIGHT

Tubs and lids are produced by polypropylene in grades approved for food packaging according to New Code for Foodstuff and beverages 1998, Chapter II, Art.26.  
Both lid and the container are food grade for human consumption.

D400 tub and lid can be produced with all colors as per the demand of the customer.  
Production is certificated according to EN ISO 9001:2000.

Unit Weight (Tub): 16,9 gr (±1)

Filling Volume: 400 ml

Unit Weight (Lid): 4,5 gr (±0,5)

Brimful Volume: 473 ml (16 oz)

**100%  
Recyclable  
PP Material**

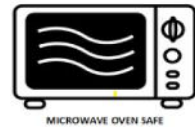

## LOGISTIC & PALLETISING

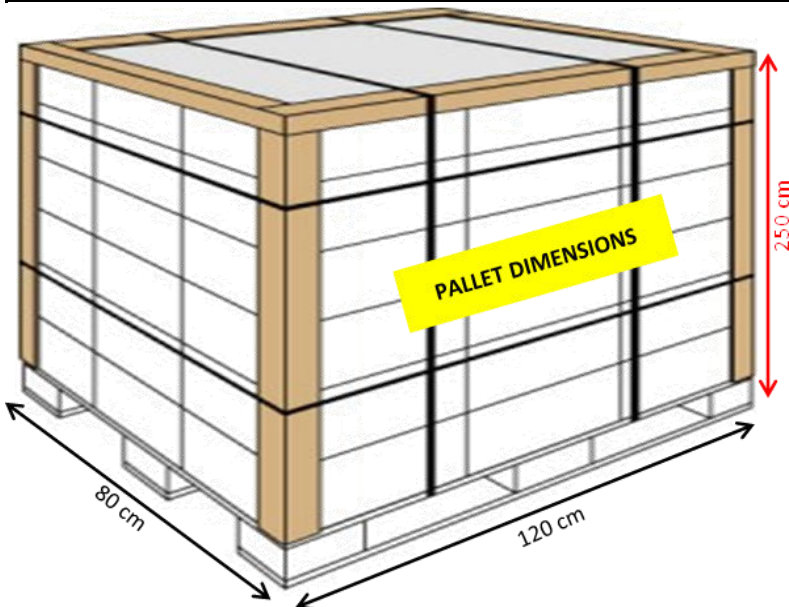

Box Dimensions (w\*l\*h) : 40\*60\*47 cm

Quantity / Box : 640 sets

**640 pieces of tubs + 640 pieces of lids packed in the same box.**

Boxes / Pallet : 20 pcs

Quantity / Pallet : 12.800 pcs

Quantity / Standard Truck : 422.400 pcs

Quantity / 20'DC Container : 112.640 pcs

Quantity / 40'HC Container : 307.200 pcs



20'DC

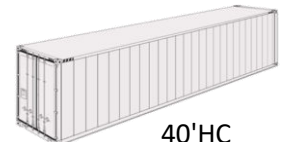

40'HC