

# PRODUCT DATA SHEET

PRODUCT CODE: DÖK380

DESCRIPTION: PP-IML Container for Food Packaging



## TECHNICAL DRAWINGS & PICTURES & IML DIE CUT DRAWINGS

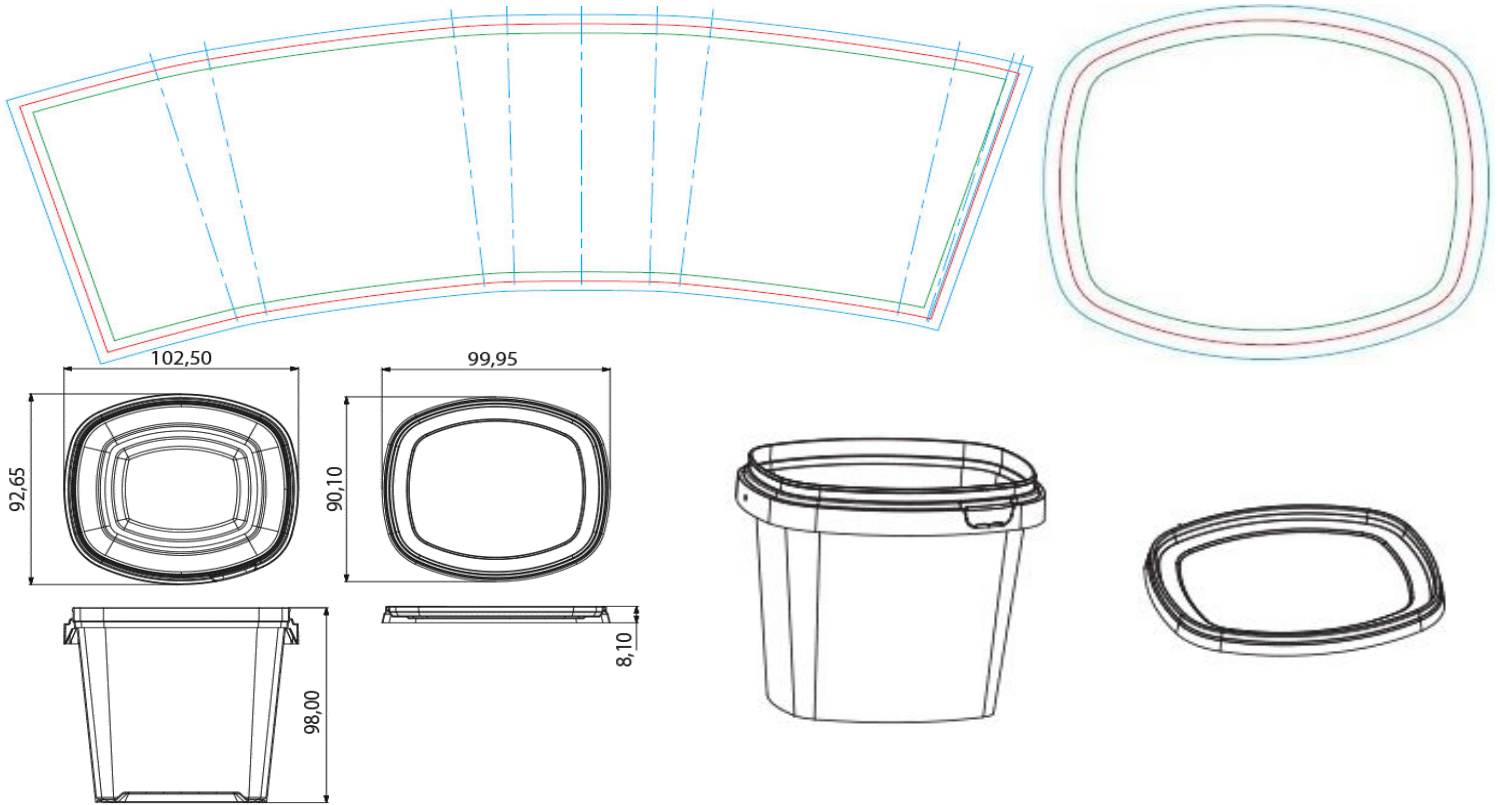

## MATERIAL, COLOR, QUALITY CONTROL and WEIGHT

Containers and lids are produced by polypropylene in grades approved for food packaging according to New Code for Foodstuff and beverages 1998, Chapter II, Art.26. Both lid and the container are food grade for human consumption.



D280 container and lid can be produced with all colors as per the demand of the customer.

Production is certificated according to EN ISO 9001:2000.

Container: 20,0 gr (±1)

Lid: 6,0 gr (±1)

Volume: 400 ml



## LOGISTIC & PALLETISING

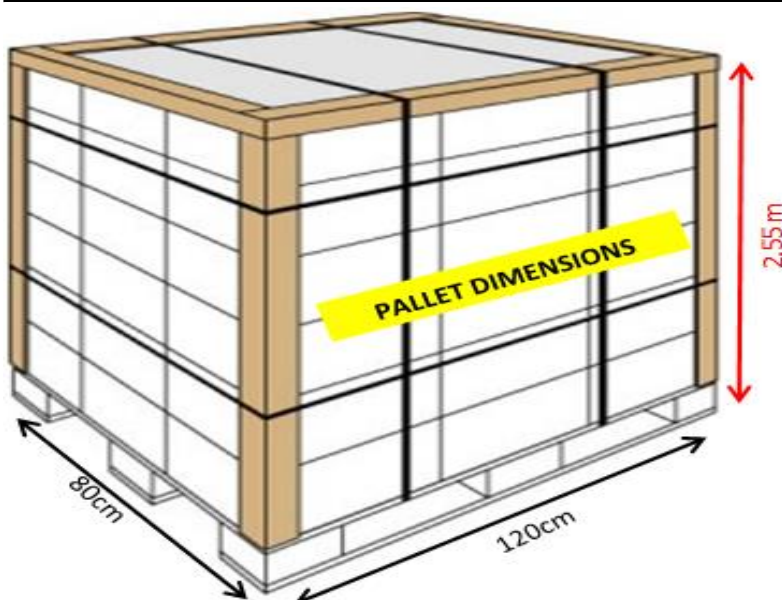

<b>Carton Box Dimensions</b>	: 43*55*60 cm (w*l*h)
<b>Quantity / Carton Box</b>	: 1.035 pcs (body)
<b>Quantity / Carton Box</b>	: 4.140 pcs (lid)
<b>Carton Boxes / Pallet</b>	: 16 pcs
<b>Quantity / Pallet</b>	: 16.560 pcs (body)
<b>Quantity / Pallet</b>	: 66.240 pcs (lid)
<b>Pallets / Standart Truck</b>	: 33 pcs

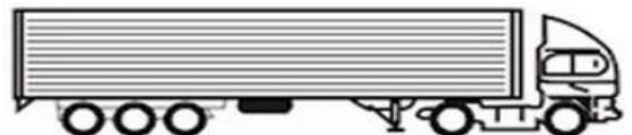

**Quantity / Standart Truck** : 437.184 pcs  
(26,4 pallets of container + 6,6 pallets of lid)