

PRODUCT DATA SHEET

PRODUCT CODE: DYK655

DESCRIPTION: PP-IML Cup for Food Packaging

$$\sum_{i=1}^{\infty} P_i$$

DivanPackaging

www.divanpackaging.com

TECHNICAL DRAWINGS & PICTURES

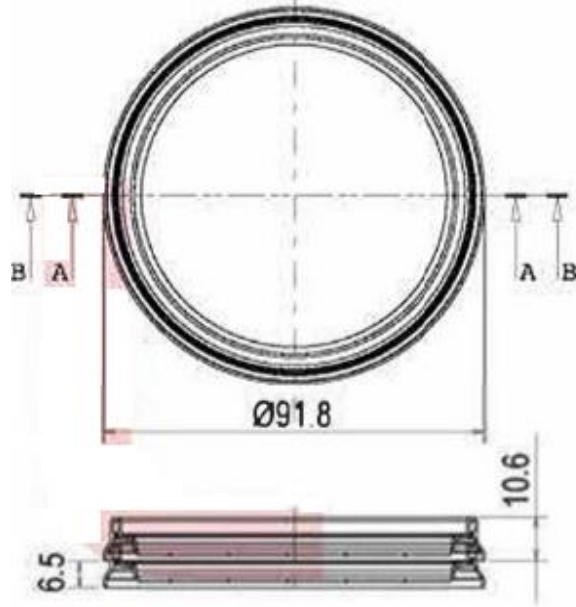
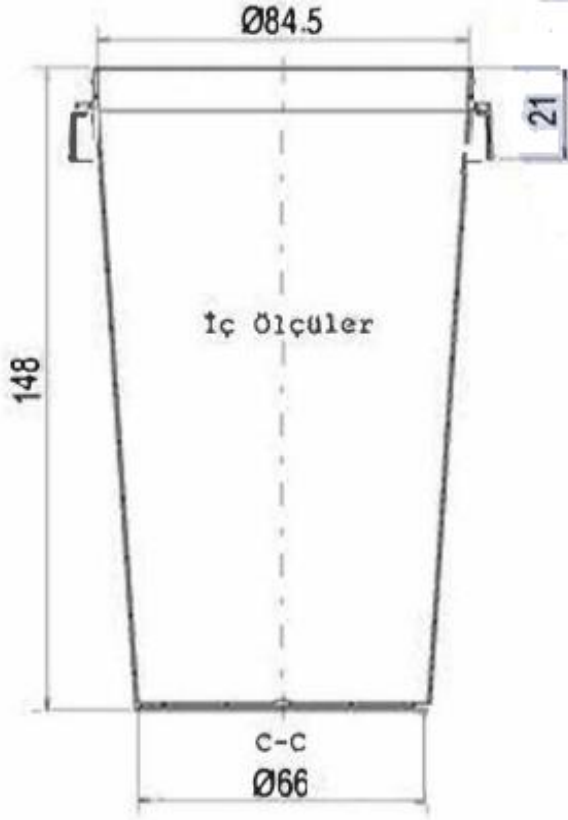

MATERIAL, COLOR, QUALITY CONTROL and WEIGHT

Cups and lids are produced by polypropylene in grades approved for food packaging according to New Code for Foodstuff and beverages 1998, Chapter II, Art.26.

Both lid and the container are food grade for human consumption.

DYK655 container and lid can be produced with all colors as per the demand of the customer.

Production is certificated according to EN ISO 9001:2000.

Container: 27 gr (±2)

Lid: 6,5 gr (±1)

Volume: 650 ml

100%
Recyclable
PP Material



LOGISTIC & PALLETISING

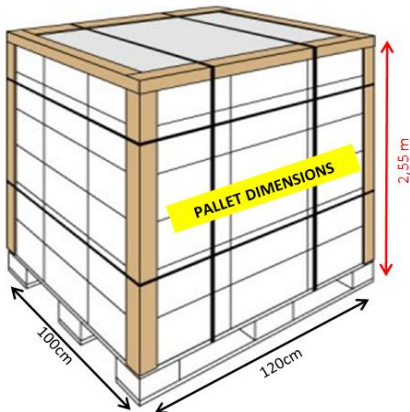

Box Dimensions (tub)	:	40*60*79 cm	(w * l * h)
Box Dimensions (lid)	:	40*50*43 cm	(w * l * h)
Boxes per Pallet (Tub)	:	15	
Boxes per Pallet (Lid)	:	30	
Quantity per Pallet	:	11.520 pieces	(Tub)
Quantity per Pallet	:	43.200 pieces	(Lid)
Quantity per Truck	:	236.340 sets	(Set = Body + Lid)
Quantity per 40'HC Container	:	190.890 sets	(Set = Body + Lid)
Quantity per 20'DC Container	:	90.900 sets	(Set = Body + Lid)



Standart Truck



20'DC

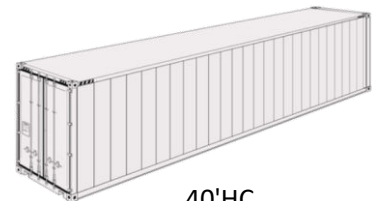

40'HC