

PRODUCT DATA SHEET

PRODUCT CODE: DYF820

DESCRIPTION: PP-IML Container for Food Packaging



TECHNICAL DRAWINGS & PICTURES & IML DIE CUT DRAWINGS

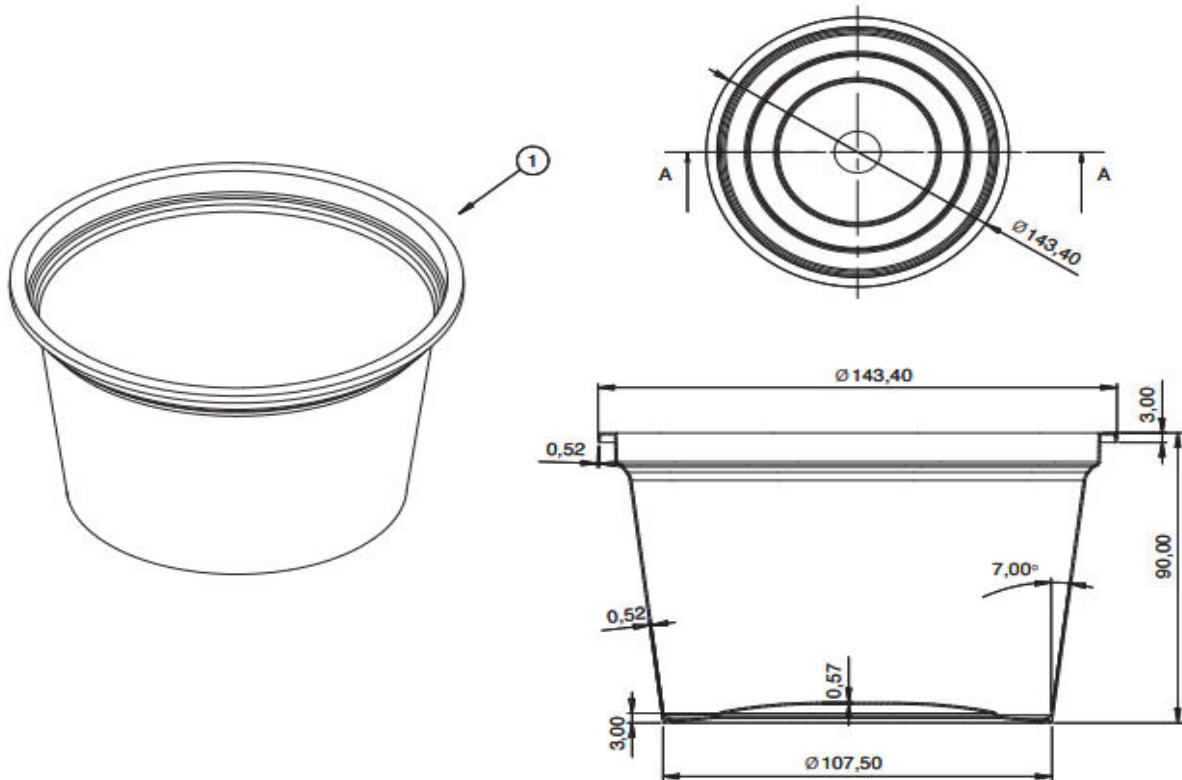

MATERIAL, COLOR, QUALITY CONTROL and WEIGHT

Containers and lids are produced by polypropylene in grades approved for food packaging according to New Code for Foodstuff and beverages 1998, Chapter II, Art.26.

Both lid and the container are food grade for human consumption.

100%
Recyclable
PP Material



DYF820 container and lid can be produced with all colors as per the demand of the customer.

Production is certificated according to EN ISO 9001:2000.

Container: 24,5 gr (±1) Lid: 13,5 gr (±1) Volume: 820 ml



LOGISTIC & PALLETISING



Carton Box Dimensions : 37*57*57 cm (body)
Quantity / Carton Box : 432 pcs (body)

Carton Box Dimensions : 55*43*60 cm (lid)
Quantity / Carton Box : 900 pcs (lid)

Quantity / 20'DC Container : 72.600 pcs
Quantity / 40'HC Container : 165.000 pcs
Quantity / Truck : 218.000 pcs

