

# PRODUCT DATA SHEET

PRODUCT CODE: DYF210

DESCRIPTION: PP-IML Container for Food Packaging



## TECHNICAL DRAWINGS & PICTURES & IML DIE CUT DRAWINGS

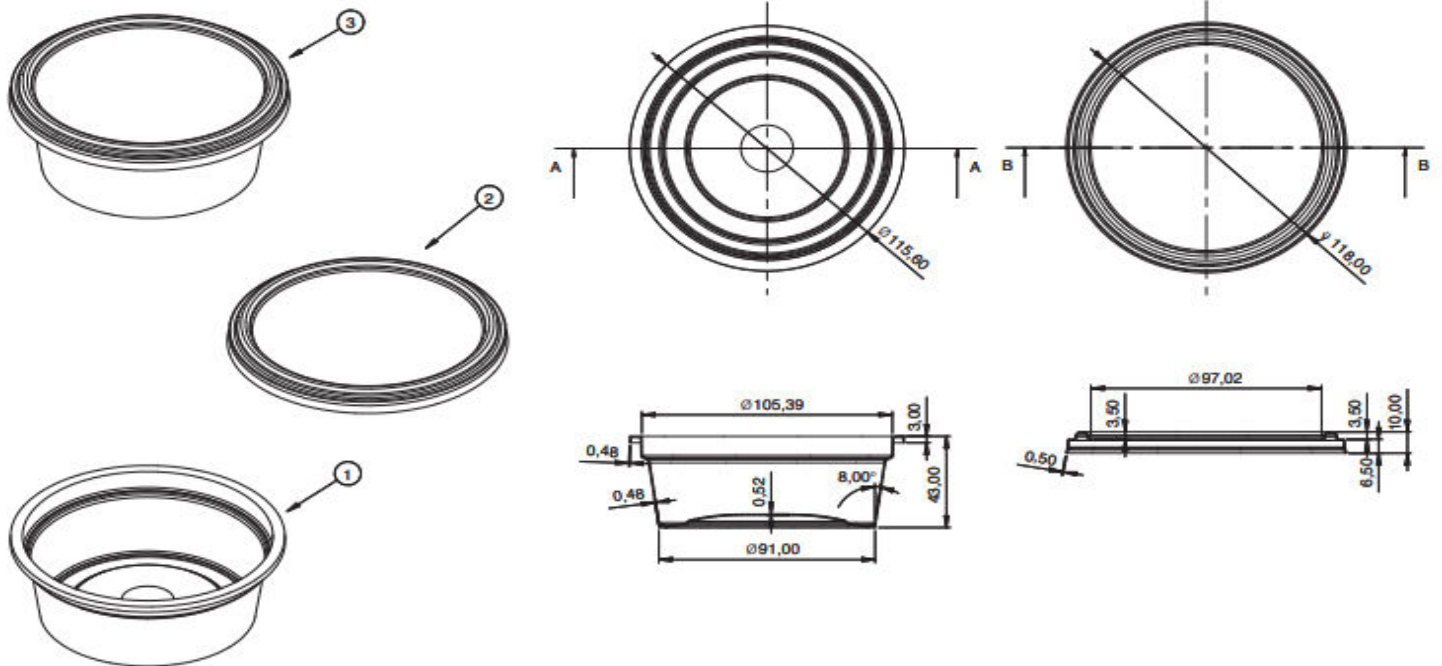

## MATERIAL, COLOR, QUALITY CONTROL and WEIGHT

Containers and lids are produced by polypropylene in grades approved for food packaging according to New Code for Foodstuff and beverages 1998, Chapter II, Art.26.  
Both lid and the container are food grade for human consumption.

100%  
 Recyclable  
 PP Material



DYF210 container and lid can be produced with all colors as per the demand of the customer.  
 Production is certificated according to EN ISO 9001:2000.

Container: 11,5 gr ( $\pm 1$ )      Lid: 6,8 gr ( $\pm 1$ )      Volume: 210 ml



## LOGISTIC & PALLETISING



Carton Box Dimensions : 37\*57\*57 cm (body)  
 Quantity / Carton Box : 750 pcs (body)

Carton Box Dimensions : 37\*57\*57 cm (lid)  
 Quantity / Carton Box : 1.680 pcs (lid)

Quantity / 20'DC Container : 137.000 pcs  
 Quantity / 40'HC Container : 310.000 pcs  
 Quantity / Truck : 409.000 pcs

