

# PRODUCT DATA SHEET

PRODUCT CODE: DÖK175

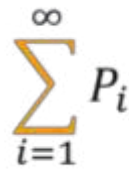

**Divan**Packaging

www.divanpackaging.com

DESCRIPTION: PP-IML Cup for Food Packaging

## TECHNICAL DRAWINGS & PICTURES

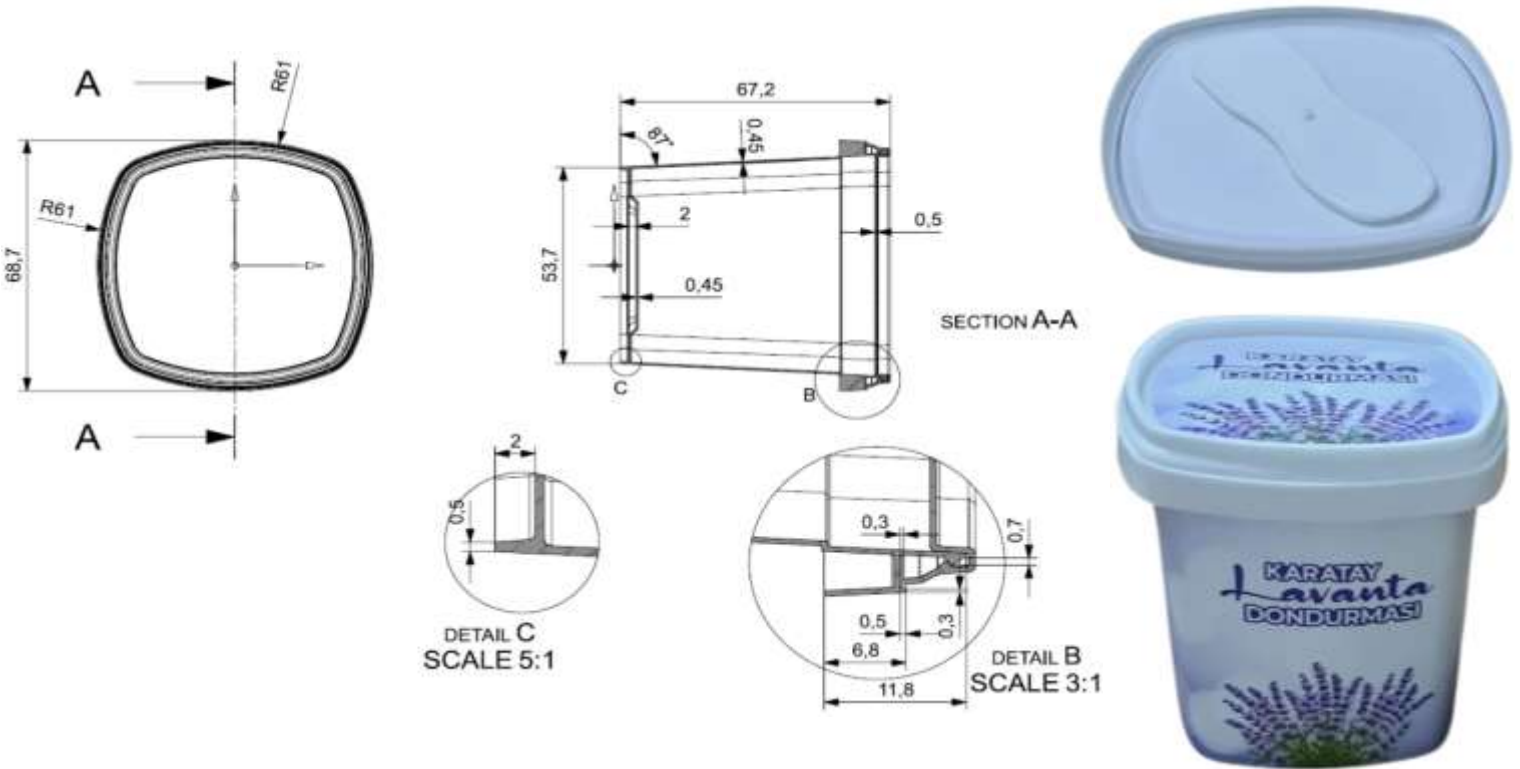

## MATERIAL, COLOR, QUALITY CONTROL and WEIGHT

Cups and lids are produced by polypropylene in grades approved for food packaging according to New Code for Foodstuff and beverages 1998, Chapter II, Art.26.

Both lid and the container are food grade for human consumption.

DÖK155 container and lid can be produced with all colors as per the demand of the customer.

Production is certificated according to EN ISO 9001:2000.

Container: 7,9 gr (±%5)      Lid: 2 gr (±%5)      Volume: 175 ml



## LOGISTIC & PALLETISING

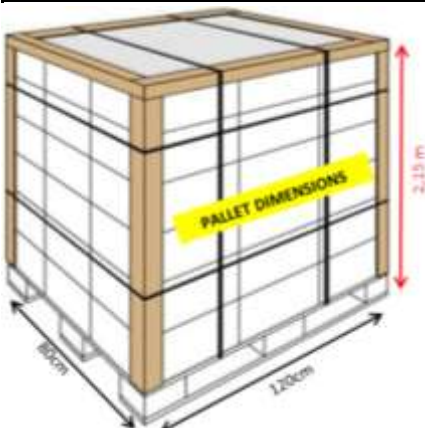

Quantity per Box : 1.344 pieces (Tub)  
Quantity per Box : 4.032 pieces (Lid)

Quantity per Pallet : 26.880 pieces (Tub)  
Quantity per Pallet : 80.640 pieces (Lid)

Quantity per Truck : 665.280 sets (Set = Body + Lid)  
Quantity per 40'HC Container : 483.840 sets (Set = Body + Lid)  
Quantity per 20'DC Container : 221.760 sets (Set = Body + Lid)

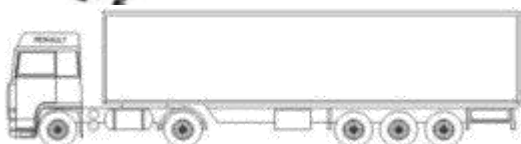

Standart Truck



20'DC



40'HC