

PRODUCT DATA SHEET

PRODUCT CODE: DYK170

DESCRIPTION: PP-IML Cup for Food Packaging

$$\sum_{i=1}^{\infty} P_i$$

DivanPackaging

www.divanpackaging.com

TECHNICAL DRAWINGS & PICTURES

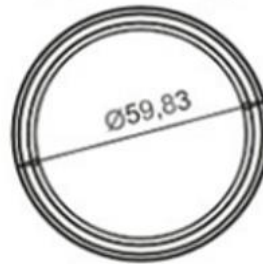
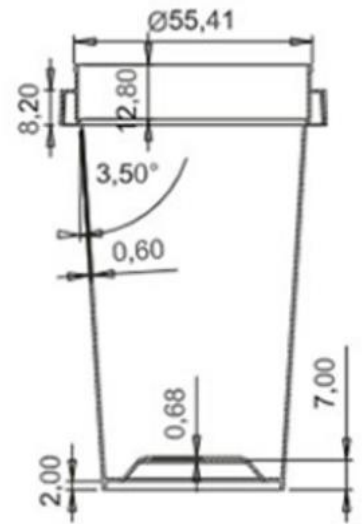
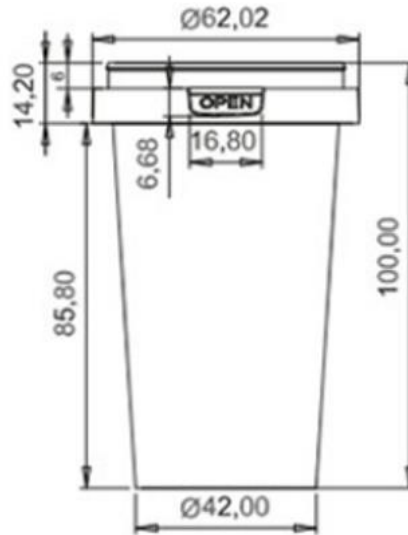

MATERIAL, COLOR, QUALITY CONTROL and WEIGHT

Cups and lids are produced by polypropylene in grades approved for food packaging according to New Code for Foodstuff and beverages 1998, Chapter II, Art.26.

Both lid and the container are food grade for human consumption.

100%
Recyclable
PP Material



DYK170 container and lid can be produced with all colors as per the demand of the customer.

Production is certificated according to EN ISO 9001:2000.

Container: 10,8 gr (±2)

Lid: 2,5 gr (±1)

Volume: 170 ml



LOGISTIC & PALLETISING

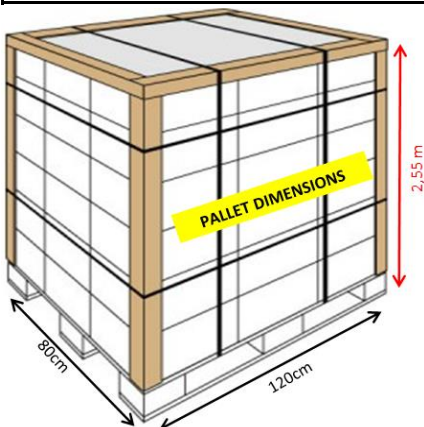

Quantity per Box : 2.442 pieces (Tub)
Quantity per Box : 4.884 pieces (Lid)

Boxes per Pallet : 16
Quantity per Pallet : 39.072 pieces (Tub)
Quantity per Pallet : 78.144 pieces (Lid)

Quantity per Truck : 859.584 sets (Set = Body + Lid)
Quantity per 40'HC Container : 625.152 sets (Set = Body + Lid)
Quantity per 20'DC Container : 286.528 sets (Set = Body + Lid)



Standart Truck



20'DC

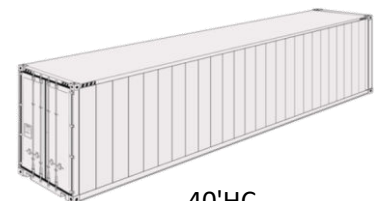

40'HC