

PRODUCT DATA SHEET

PRODUCT CODE: DÖF301

DESCRIPTION: PP-IML Cup for Food Packaging

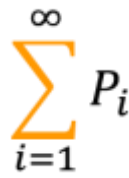

DivanPackaging

www.divanpackaging.com

TECHNICAL DRAWINGS & PICTURES

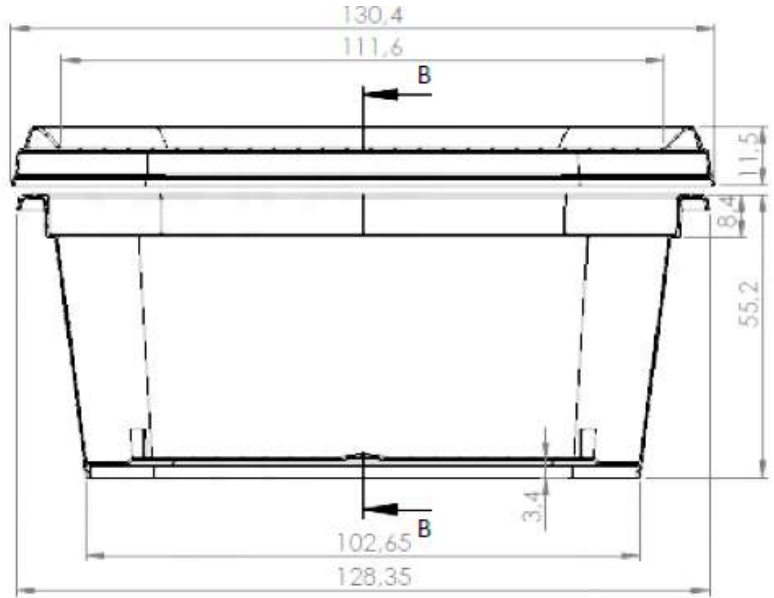

MATERIAL, COLOR, QUALITY CONTROL and WEIGHT

Tubs and lids are produced by polypropylene in grades approved for food packaging according to New Code for Foodstuff and beverages 1998, Chapter II, Art.26.

Both lid and tube are food grade for human consumption.

DÖF301 tub and lid can be produced with all colors as per the demand of the customer.

Production is certificated according to EN ISO 9001:2000.

Tub: 12,5 gr (±2)

Lid: 7,5 gr (±1)

Volume: 300 ml



LOGISTIC & PALLETISING

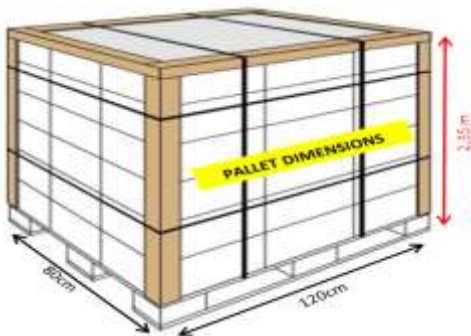

Box Dimensions (tub)	:	58*40*47 cm	(w * l * h)
Box Dimensions (lid)	:	58*40*47 cm	(w * l * h)
Boxes per Pallet (tub)	:	20	
Boxes per Pallet (lid)	:	20	
Quantity per Pallet	:	14.280 pieces	(Tub)
Quantity per Pallet	:	27.600 pieces	(Lid)
Quantity per Truck	:	310.554 sets	(Set = Tub + Lid)
Quantity per 40'HC Container	:	235.268 sets	(Set = Tub + Lid)
Quantity per 20'DC Container	:	103.518 sets	(Set = Tub + Lid)

