

PRODUCT DATA SHEET

PRODUCT CODE: DYF240

DESCRIPTION: PP Cup for Food Packaging



TECHNICAL DRAWINGS & PICTURES & IML DIE CUT DRAWINGS

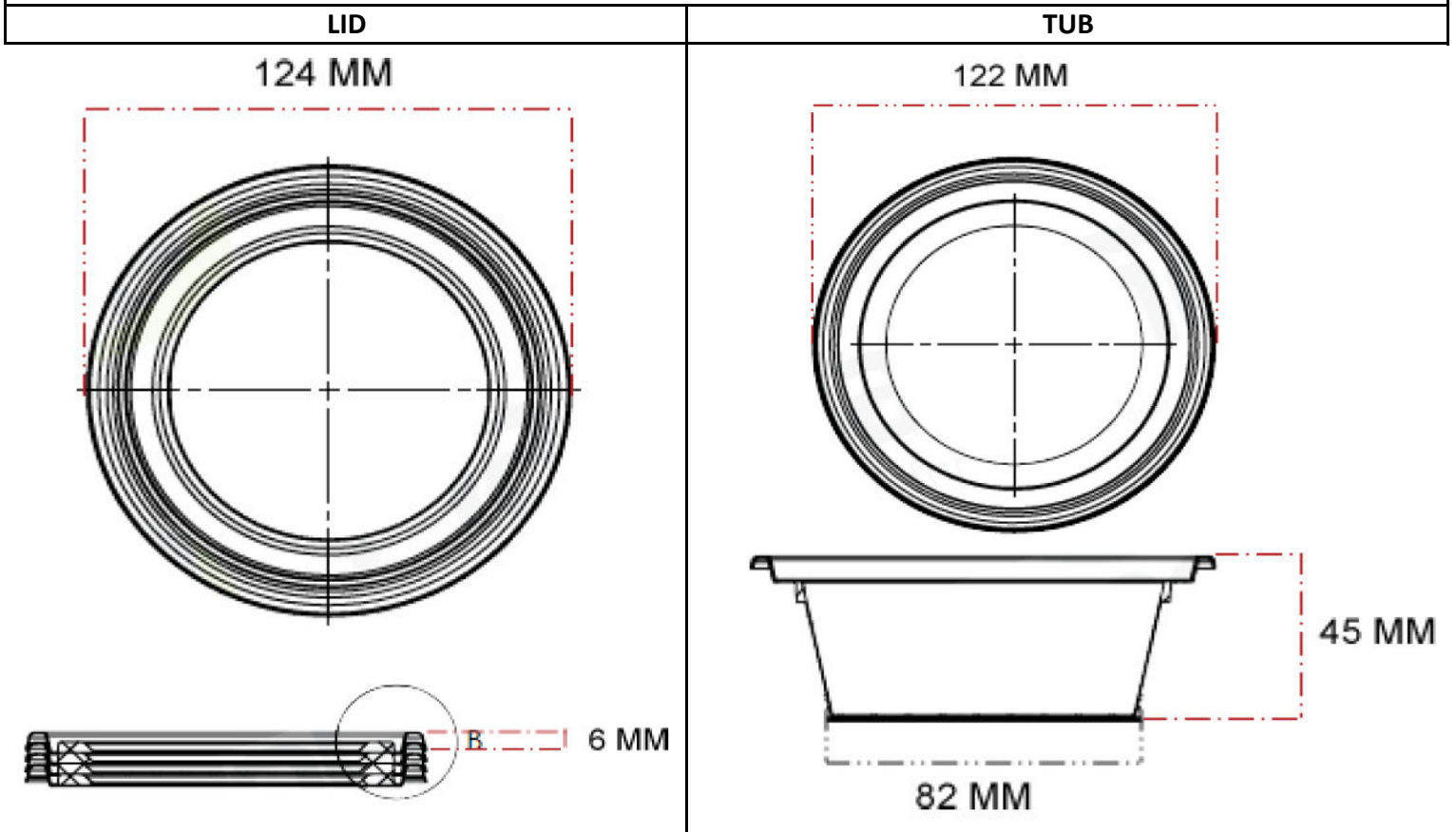

MATERIAL, COLOR, QUALITY CONTROL and WEIGHT

Containers and lids are produced by polypropylene in grades approved for food packaging according to New Code for Foodstuff and beverages 1998, Chapter II, Art.26.

Both lid and the container are food grade for human consumption.

100%
Recyclable
PP Material



DYF240 cup and lid can be produced with all colors as per the demand of the customer.

Production is certificated according to EN ISO 9001:2000.

Container: 11,5 gr (±%5) Lid: 8,5 gr (±%5) Brimful Volume: 290 ml Filling Volume: 220 ml



LOGISTIC & PALLETISING

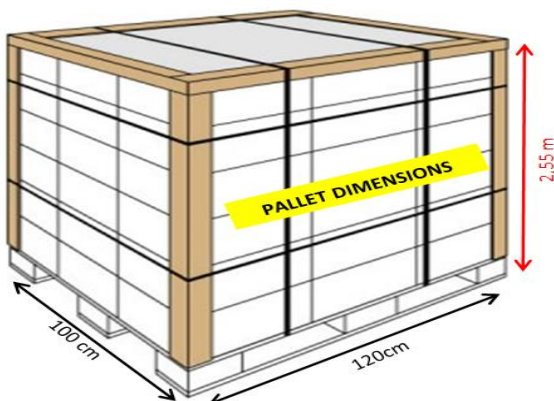

Box Dimensions	: 39*39*29 cm	(w * l * h)
Quantity per Box	: 225 pieces	(sets)
Boxes per Pallet	: 66	
Quantity per Pallet	: 14.850 pieces	(sets)
Quantity per Truck	: 386.100 pieces	(sets)
Quantity per 40'HC Container	: 311.850 pieces	(sets)
Quantity per 20'DC Container	: 148.500 pieces	(sets)

