

PRODUCT DATA SHEET

PRODUCT CODE: TX01

$$\sum_{i=1}^{\infty} P_i$$

DivanPackaging

www.divanpackaging.com

DESCRIPTION: PP-IML Container for Food Packaging

TECHNICAL DRAWINGS & PICTURES

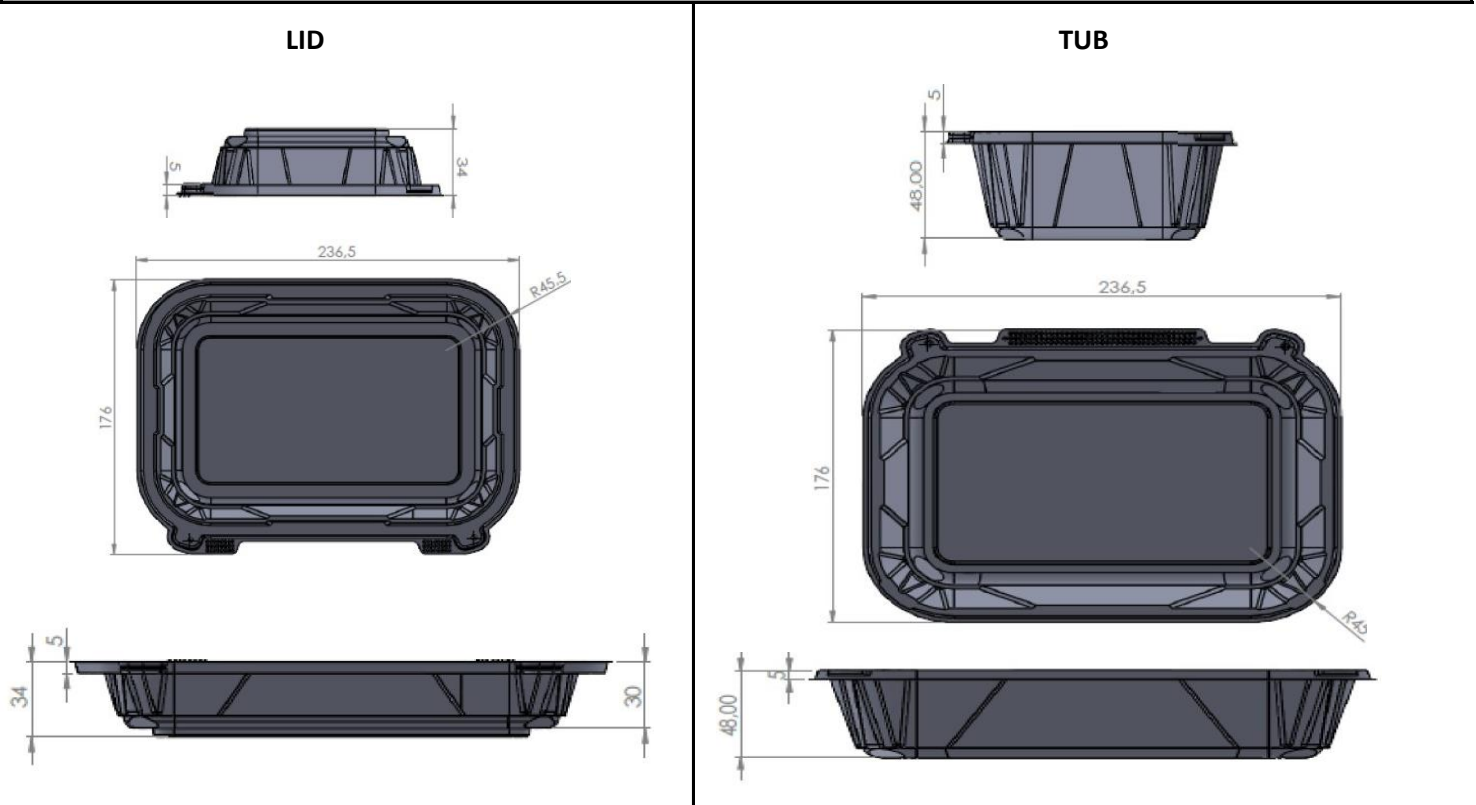

MATERIAL, COLOR, QUALITY CONTROL and WEIGHT

Containers and lids are produced by PP in grades approved for food packaging according to New Code for Foodstuff and beverages 1998, Chapter II, Art.26. Both lid and the container are food grade for human consumption.

TX01 container and lid can be produced with all colors as per the demand of the customer. Production is certificated according to EN ISO 9001:2000. Container: 21,5 gr (±1) Lid: 20,5 gr (±1)

**100%
Recyclable
PP Material**



LOGISTIC & PALLETISING

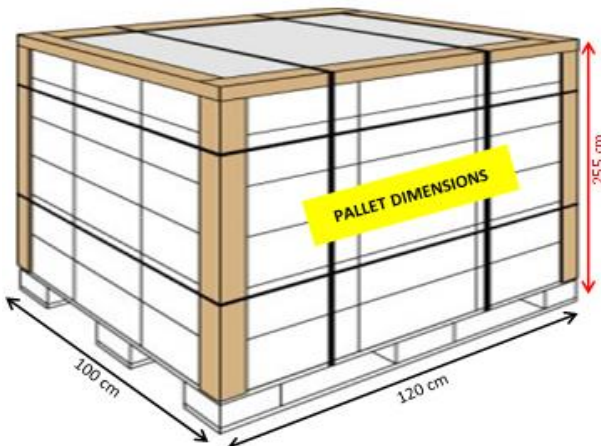

Box Dimensions (tub)	:	48*38*29 cm	(w * l * h)
Box Dimensions (lid)	:	48*38*29 cm	(w * l * h)
Boxes per Pallet (tub)	:	48	
Boxes per Pallet (lid)	:	48	
Quantity per Pallet	:	14.400 pieces	(Tub)
Quantity per Pallet	:	14.400 pieces	(Lid)
Quantity per Truck	:	187.200 sets	(Set = Body + Lid)
Quantity per 40'HC Container	:	151.200 sets	(Set = Body + Lid)
Quantity per 20'DC Container	:	63.000 sets	(Set = Body + Lid)



20'DC

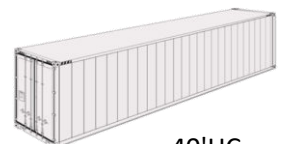

40'HC