

PRODUCT DATA SHEET

PRODUCT CODE: DÖK620

DESCRIPTION: PP-IML Tub & Lid for Food Packaging



TECHNICAL DRAWINGS & PICTURES

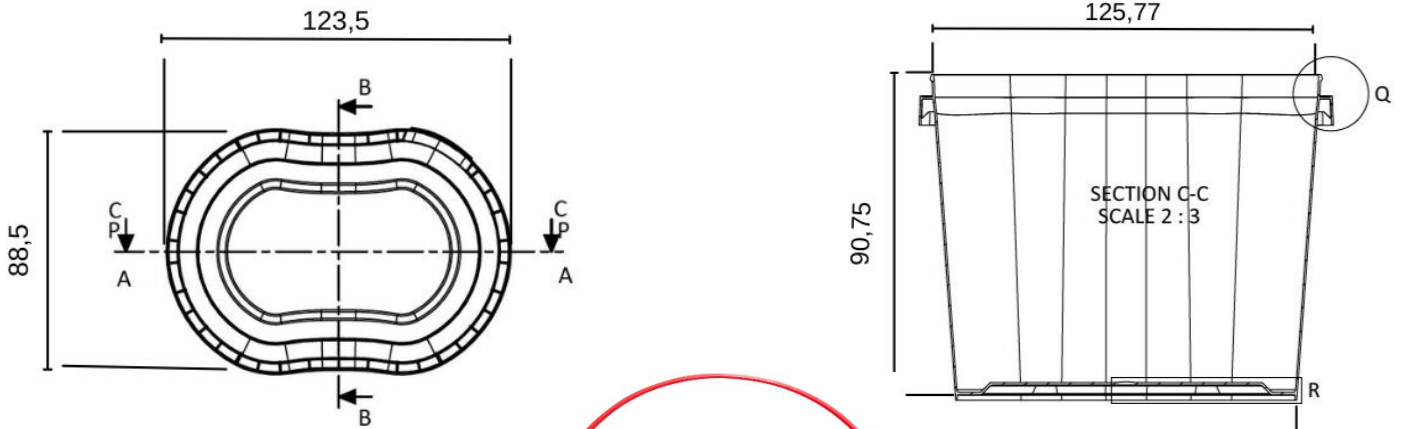

MATERIAL, COLOR, QUALITY CONTROL and WEIGHT

Containers and lids are produced by polypropylene in grades approved for food packaging according to New Code for Foodstuff and beverages 1998, Chapter II, Art.26.

Both tub and the lid are food grade for human consumption.

DÖK620 tub and lid can be produced with all colors as per the demand of the customer.

Production is certificated according to EN ISO 9001:2000.

Tub: 22 gr (±1)

Lid: 7,25 gr (±1)

Filling Volume: 620 ml

100%
Recyclable
PP Material



LOGISTIC & PALLETISING

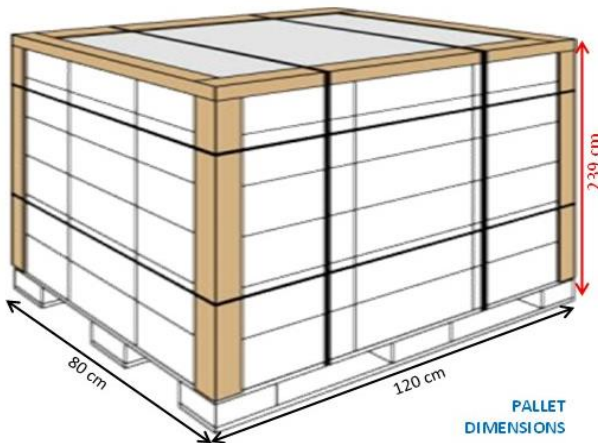

PALLET DIMENSIONS

Box Dimensions (w*l*h) (Tub)	: 37*57*56,5 cm
Box Dimensions (w*l*h)(Lid)	: 37*57*56,5 cm
Quantity / Box (Tub)	: 537 pcs
Quantity / Box (Lid)	: 2.685 pcs
Boxes / Pallet	: 16 pcs
Quantity / Pallet	: 8.900 pcs (Tub+Lid)
Quantity / Standard Truck	: 293.700 pcs
Quantity / 20'DC Container	: 97.900 pcs
Quantity / 40'HC Container	: 222.500 pcs

