

PRODUCT DATA SHEET

PRODUCT CODE: DKF5001

DESCRIPTION: PP-IML Container for Food Packaging

$$\sum_{i=1}^{\infty} P_i$$

DivanPackaging

www.divanpackaging.com

TECHNICAL DRAWINGS & PICTURES

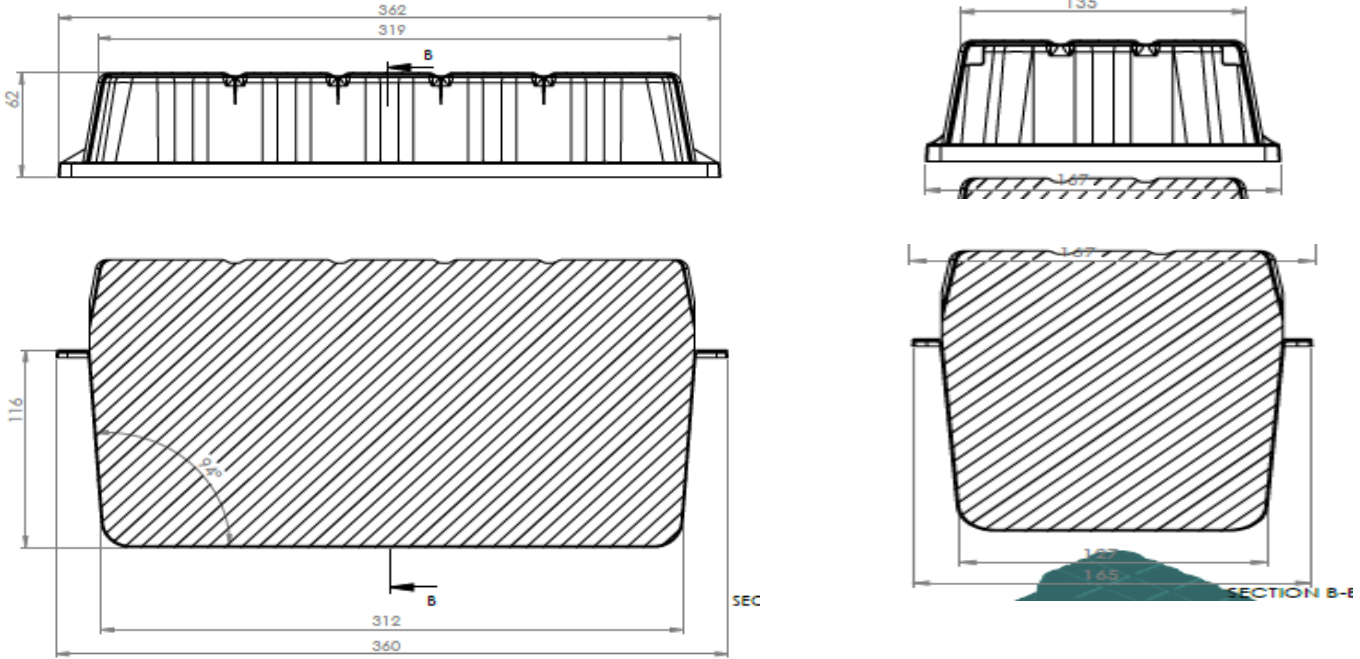

MATERIAL, COLOR, QUALITY CONTROL and WEIGHT

Containers and lids are produced by polypropylene in grades approved for food packaging according to New Code for Foodstuff and beverages 1998, Chapter II, Art.26.
Both lid and the container are food grade for human consumption.

DKF5001 container and lid can be produced with all colors as per the demand of the customer
 Production is certificated according to EN ISO 9001:2000.

Container: 125 gr (±4) Lid: 76 gr (±2) Volume: 5220 ml

100%
 Recyclable
 PP Material

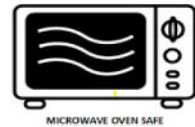

LOGISTIC & PALLETISING

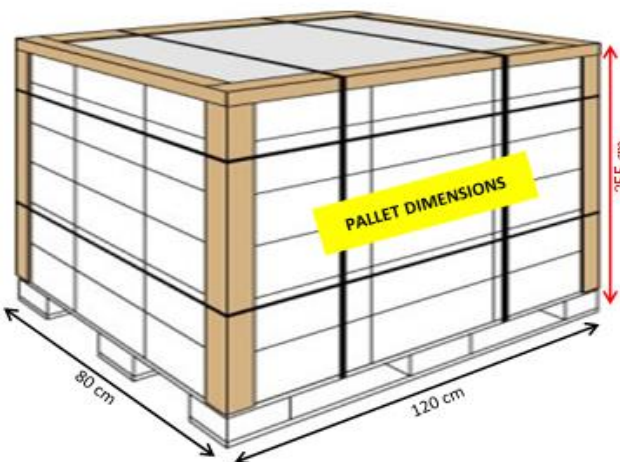

Box Dimensions (tub)	:	60*80*40 cm	(w * l * h)
Box Dimensions (lid)	:	40*60*57 cm	(w * l * h)
Boxes per Pallet (tub)	:	12	
Boxes per Pallet (lid)	:	16	
Quantity per Pallet	:	1.080 pieces	(Tub)
Quantity per Pallet	:	2.240 pieces	(Lid)
Quantity per Truck	:	24.030 sets	(Set = Body + Lid)
Quantity per 40'HC Container	:	18.215 sets	(Set = Body + Lid)
Quantity per 20'DC Container	:	8.010 sets	(Set = Body + Lid)

