

PRODUCT DATA SHEET

PRODUCT CODE: DYK307

DESCRIPTION: PP-IML Container for Food Packaging



TECHNICAL DRAWINGS & PICTURES

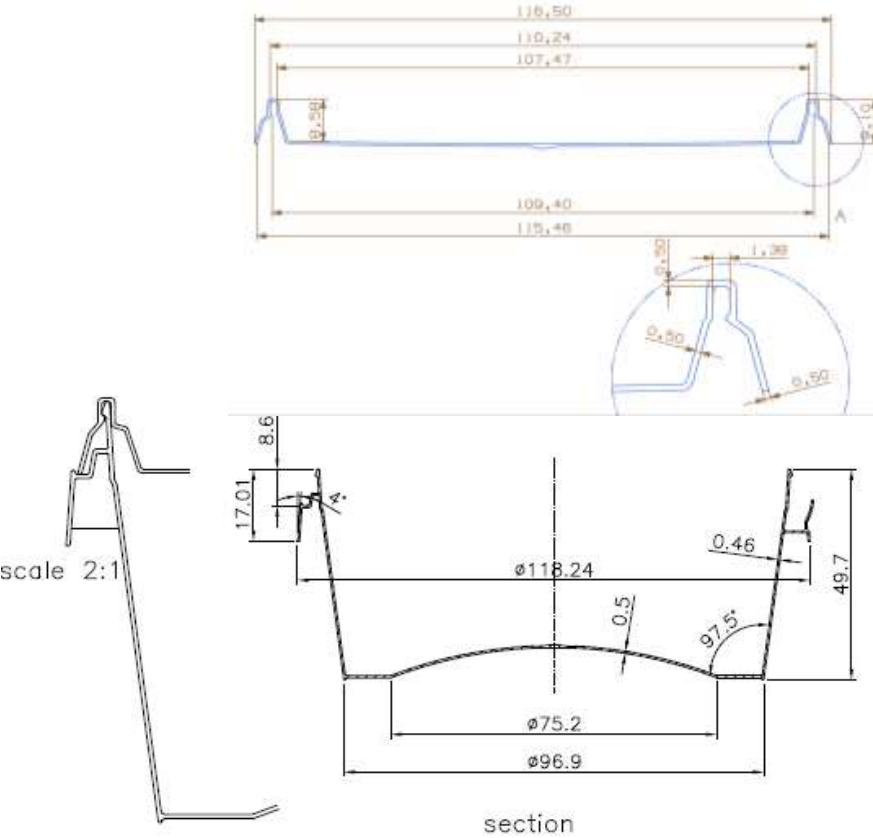

MATERIAL, COLOR, QUALITY CONTROL and WEIGHT

Containers and lids are produced by polypropylene in grades approved for food packaging according to New Code for Foodstuff and beverages 1998, Chapter II, Art.26.

Both lid and the container are food grade for human consumption.

DYK307 container and lid can be produced with all colors as per the demand of the customer.

Production is certificated according to EN ISO 9001:2000.

Container: 18,5 gr (± 2) Lid: 9 gr (± 1) Volume: 250 ml



LOGISTIC & PALLETISING

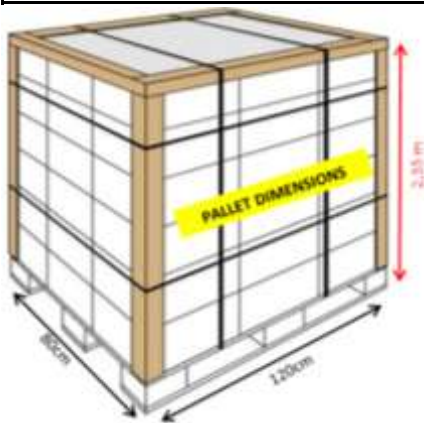

Box Dimensions	:	40*60*44 cm	(w * l * h)
Boxes per Pallet	:	20	
Quantity per Pallet	:	7.800 pieces	(Tub)
Quantity per Pallet	:	20.700 pieces	(Lid)
Quantity per Truck	:	186.900 sets	(Set = Body + Lid)
Quantity per 40'HC Container	:	141.500 sets	(Set = Body + Lid)
Quantity per 20'DC Container	:	62.300 sets	(Set = Body + Lid)

