

PRODUCT DATA SHEET

PRODUCT CODE: DYK9000

DESCRIPTION: PP-IML Container for Food Packaging



TECHNICAL DRAWINGS & PICTURES

CONTAINER

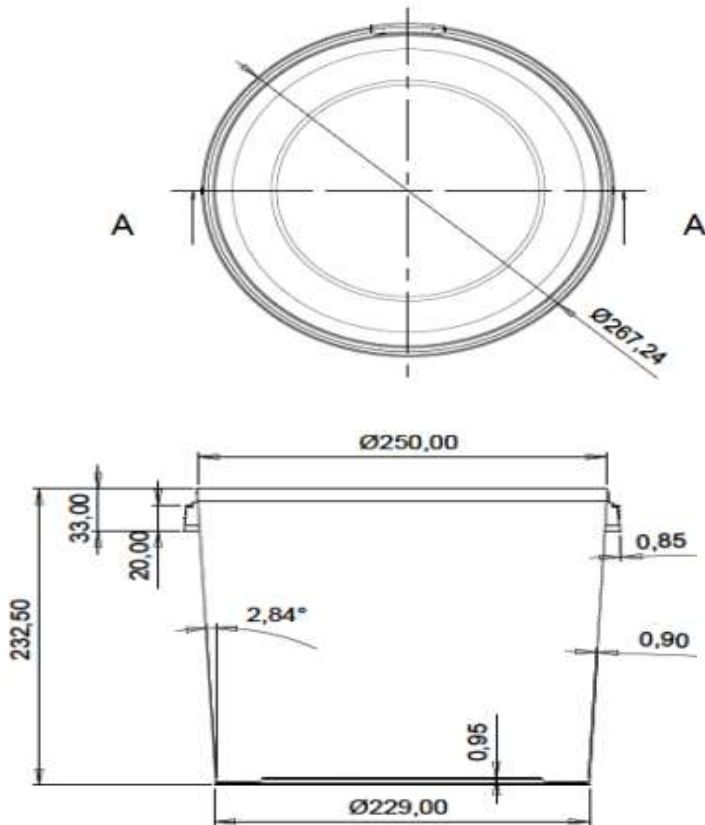

LID

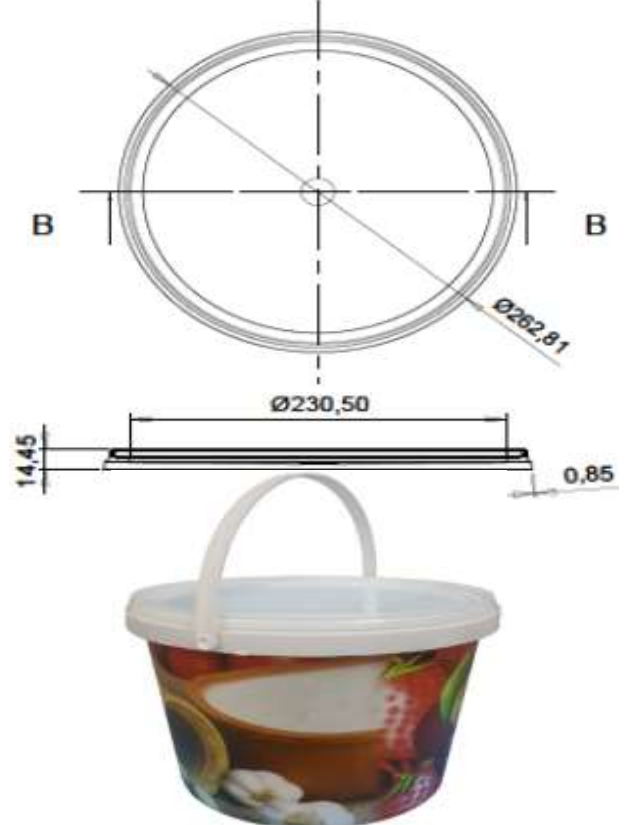

MATERIAL, COLOR, QUALITY CONTROL and WEIGHT

Containers and lids are produced by polypropylene in grades approved for food packaging according to New Code for Foodstuff and beverages 1998, Chapter II, Art.26.

Both lid and the container are food grade for human consumption.

DYK9000 container and lid can be produced with all colors as per the demand of the customer.

Production is certificated according to EN ISO 9001:2000.

Container: 210 gr (±2)

Lid: 53 gr (±2)

Volume: 9000 ml



LOGISTIC & PALLETISING

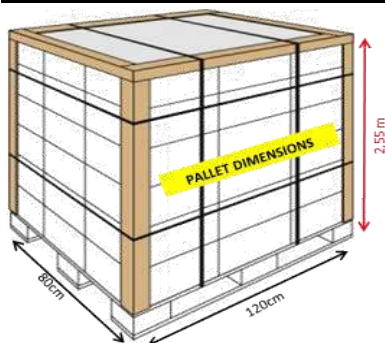

| | | | |
|------------------------------|---|-----------------|--------------------|
| Box Dimensions (tub) | : | 78*118*110,5 cm | (w * l * h) |
| Box Dimensions (lid) | : | 78*118*110,5 cm | (w * l * h) |
| Boxes per Pallet | : | 20 | |
| Quantity per Pallet | : | 34.800 pieces | (Tub) |
| Quantity per Pallet | : | 30.800 pieces | (Lid) |
| Quantity per Truck | : | 539.000 sets | (Set = Body + Lid) |
| Quantity per 40'HC Container | : | 392.000 sets | (Set = Body + Lid) |
| Quantity per 20'DC Container | : | 180.000 sets | (Set = Body + Lid) |

