

PRODUCT DATA SHEET

PRODUCT CODE: DYK5000

DESCRIPTION: PP-IML Container for Food Packaging



TECHNICAL DRAWINGS & PICTURES

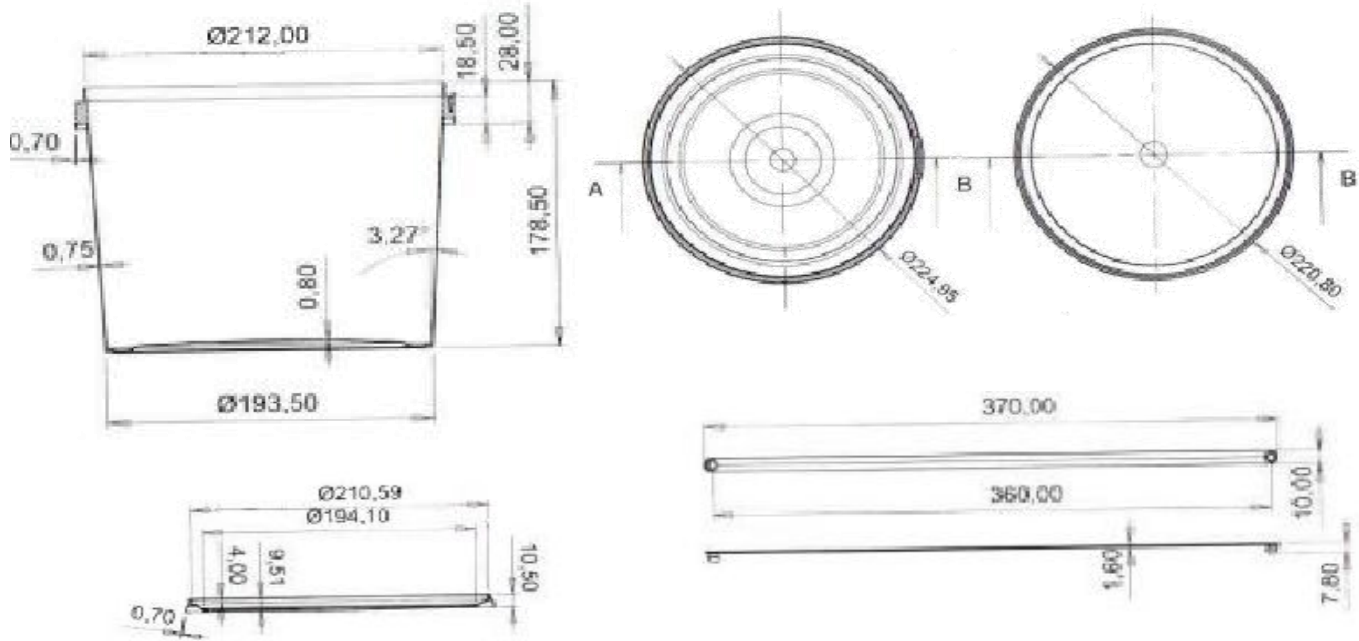

MATERIAL, COLOR, QUALITY CONTROL and WEIGHT

Containers and lids are produced by polypropylene in grades approved for food packaging according to New Code for Foodstuff and beverages 1998, Chapter II, Art.26.

Both lid and the container are food grade for human consumption.

DYK5000 container and lid can be produced with all colors as per the demand of the customer.

Production is certificated according to EN ISO 9001:2000.

Container: 128,8gr (±5%)

Lid: 35,1 gr (±5%)

Volume: 5000 ml

**100%
Recyclable
PP Material**



LOGISTIC & PALLETISING

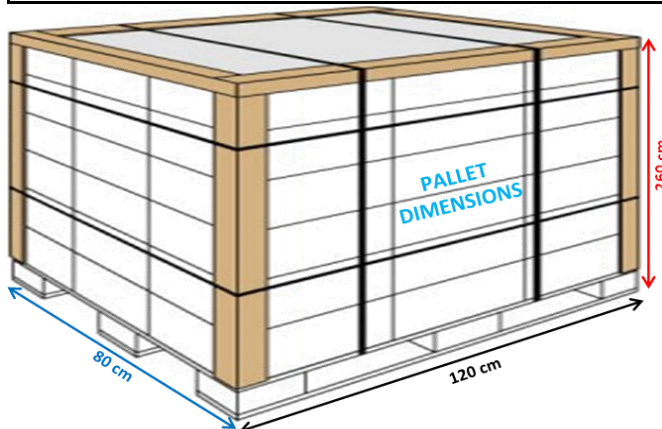

- Carton Box Dimensions** : 80*120*115 cm (w*I*h)
- Quantity / Carton Box** : 495 pcs
- buckets and lids are packed in the same carton box*
- 1 carton box includes 495 pcs of buckets and 495 pcs of lids*
- Carton Boxes / Pallet** : 2 pcs
- Quantity / Pallet** : **990 pcs**
- Quantity / Standart Truck** : 32.670 pcs
- Quantity / 20'DC Container** : 10.890 pcs
- Quantity / 40'HC Container** : 23.760 pcs

