

# PRODUCT DATA SHEET

PRODUCT CODE: DYK2000

DESCRIPTION: PP-IML Bucket for Food Packaging



## TECHNICAL DRAWINGS

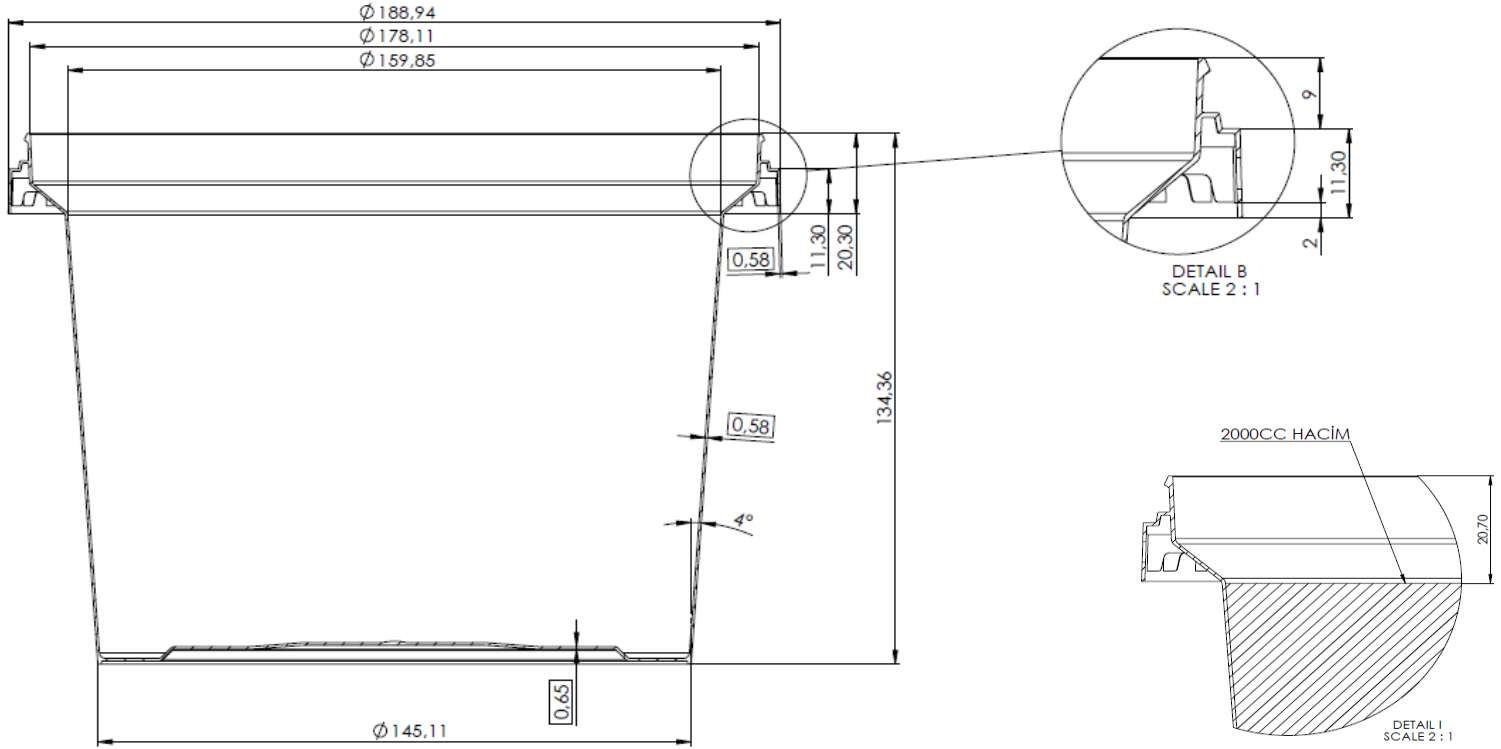

## MATERIAL, COLOR, QUALITY CONTROL and WEIGHT

Containers and lids are produced by polypropylene in grades approved for food packaging according to New Code for Foodstuff and beverages 1998, Chapter II, Art.26. Both lid and the container are food grade for human consumption.



DYK2000 PP IML Bucket and its PP IML lid can be produced with all colors as per the demand of the customer. Production is certificated according to EN ISO 9001:2000.

Bucket: 55,0 gr (±1)

Lid: 21,0 gr (±1)

Handle: 3,0 gr (±0,5)

Volume: 2000 ml



## LOGISTIC & PALLETISING

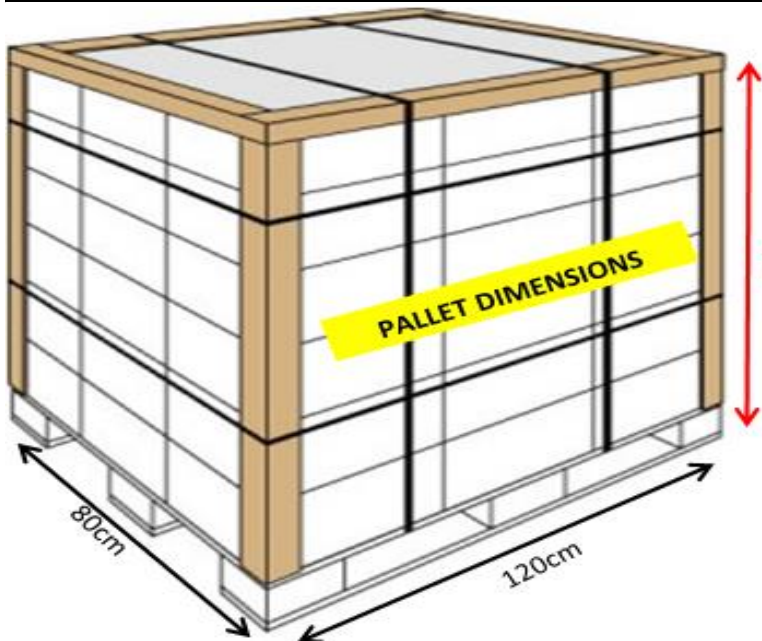

**Carton Box Dimensions** : 80\*120\*115 cm (w\*I\*h)

**Quantity / Carton Box** : 1.152 pcs (sets)

**Carton Boxes / Pallet** : 2 pcs

(One carton box is located on the other one.)

There is an additional pallet located between two carton boxes to easify unloading. )

**Quantity / Pallet** : 2.304 pcs (sets)

**Pallets / Standart Truck** : 33 pcs

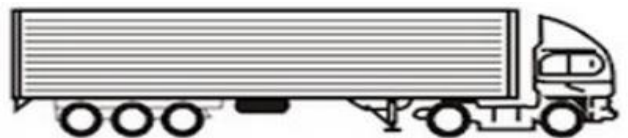

**Quantity / Standart Truck** : 76.032 pcs (sets)