

PRODUCT DATA SHEET

DYK1500: 1.5L PP IML TUB & PP IML LID

TECHNICAL DRAWINGS

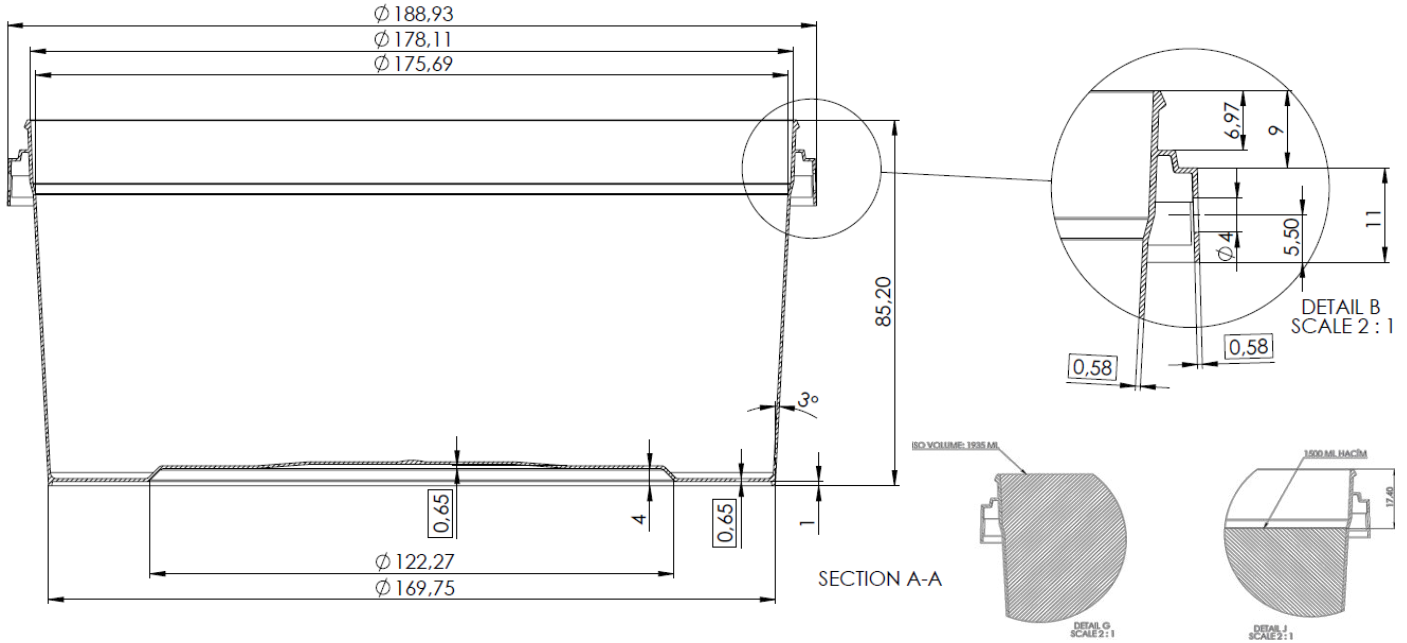

MATERIAL, COLOR, QUALITY CONTROL and WEIGHT

Containers and lids are produced by polypropylene in grades approved for food packaging according to New Code for Foodstuff and beverages 1998, Chapter II, Art.26. Both lid and the container are food grade for human consumption.



DYK1500 tub and lid can be produced with all colors as per the demand of the customer.

Production is certificated according to EN ISO 9001:2000.

Tub with Handle: 52,3 gr (± 1)

Lid: 24,4 gr (± 1)

Volume: 1.500 ml



LOGISTIC & PALLETISING

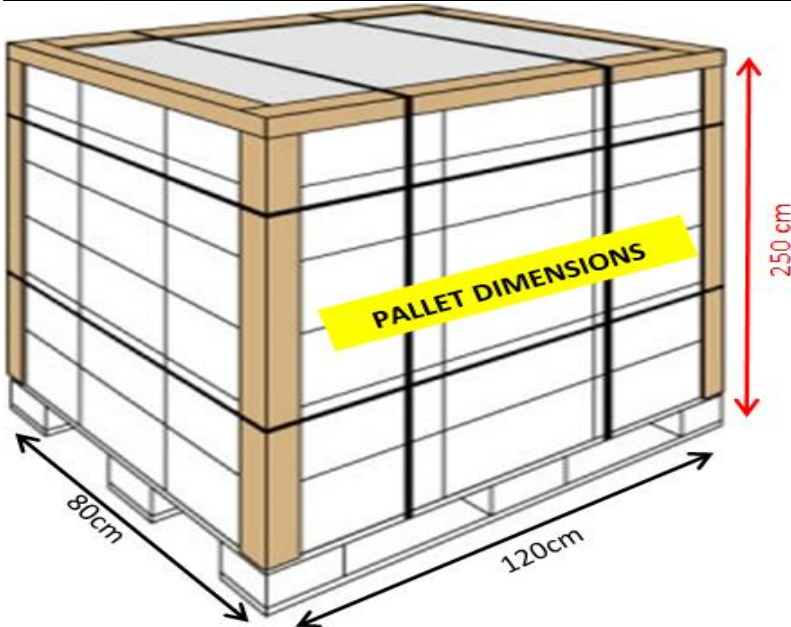

Carton Box Dimensions	: 80*120*115 cm
Carton Boxes per Pallet	: 2
Quantity / Carton Box	: 1.080 pcs (tubs&lids)
Carton Boxes / Pallet	: 2 pieces
Quantity / Pallet	: 2.160 pcs (tubs&lids)
Pallets / 20'DC Cont	: 11 pcs
Pallets / 40'HC Cont	: 24 pcs
Pallets / Standart Truck	: 33 pcs
Quantity / 20'DC Cont	: 23.760 pcs (tubs&lids)
Quantity / 40'HC Cont	: 51.840 pcs (tubs&lids)
Quantity / Truck	: 71.280 pcs (tubs&lids)

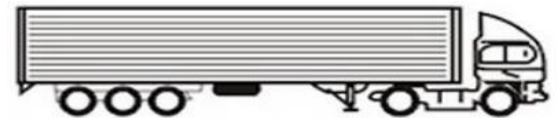

Divan Ambalaj Plastik ve Gıda San.Tic.Ltd.Şti.

İkitelli OSB Giyim Sanatkarları Sit.3.Ada A Blok No:207 Başakşehir 34490 İstanbul – Turkey

Tel1: +90 (212) 488 28 28 Tel2: +90 (212) 671 01 51 Gsm: +90 (542) 685 47 00

www.divanambalaj.com info@divanambalaj.com