

PRODUCT DATA SHEET

PRODUCT CODE: DYK125

DESCRIPTION: PP-IML Cup for Food Packaging



TECHNICAL DRAWINGS & PICTURES

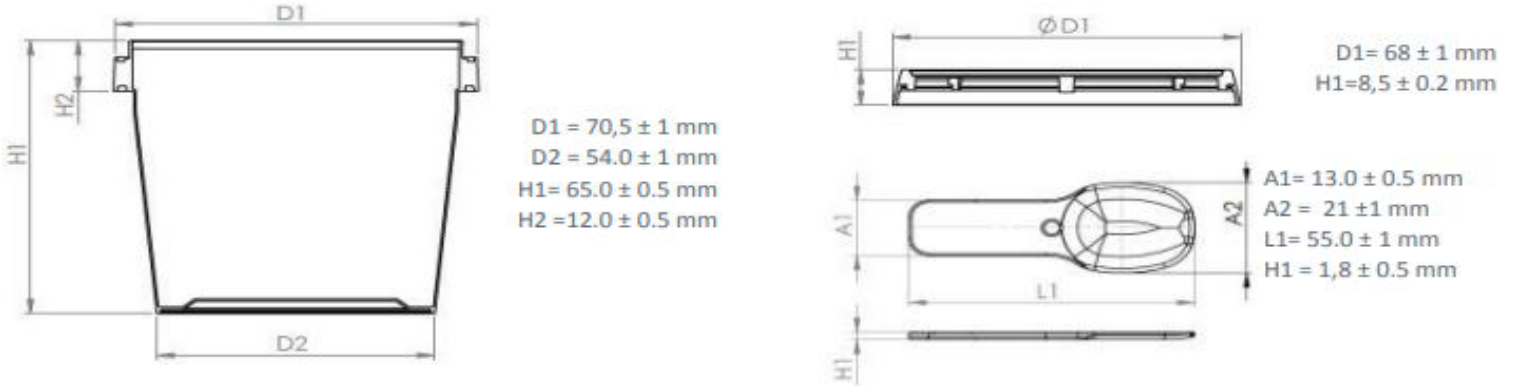

MATERIAL, COLOR, QUALITY CONTROL and WEIGHT

Tubs and lids are produced by polypropylene in grades approved for food packaging according to New Code for Foodstuff and beverages 1998, Chapter II, Art.26.

Both lid and tube are food grade for human consumption.

DYK125 tub and lid can be produced with all colors as per the demand of the customer.

Production is certificated according to EN ISO 9001:2000.

Tub: 8,5 gr (±1)

Lid: 3,5 gr (±0.5)

Volume: 125 ml

100%
Recyclable
PP Material

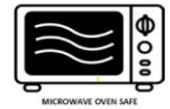

LOGISTIC & PALLETISING

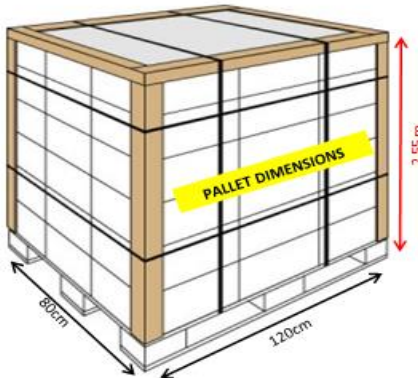

Box Dimensions (tub)	:	40*60*48 cm	(w * l * h)
Box Dimensions (lid)	:	40*40*46 cm	(w * l * h)
Boxes per Pallet (tub)	:	20	
Boxes per Pallet (lid)	:	30	
Quantity per Pallet	:	29.400 pieces	(Tub)
Quantity per Pallet	:	85.500 pieces	(Lid)
Quantity per Truck	:	721.500 sets	(Set = Tub + Lid)
Quantity per 40'HC Container	:	524.700 sets	(Set = Tub + Lid)
Quantity per 20'DC Container	:	240.500 sets	(Set = Tub + Lid)

