

PRODUCT DATA SHEET

PRODUCT CODE: DYK1005

DESCRIPTION: PP-IML Container for Food Packaging



TECHNICAL DRAWINGS & PICTURES

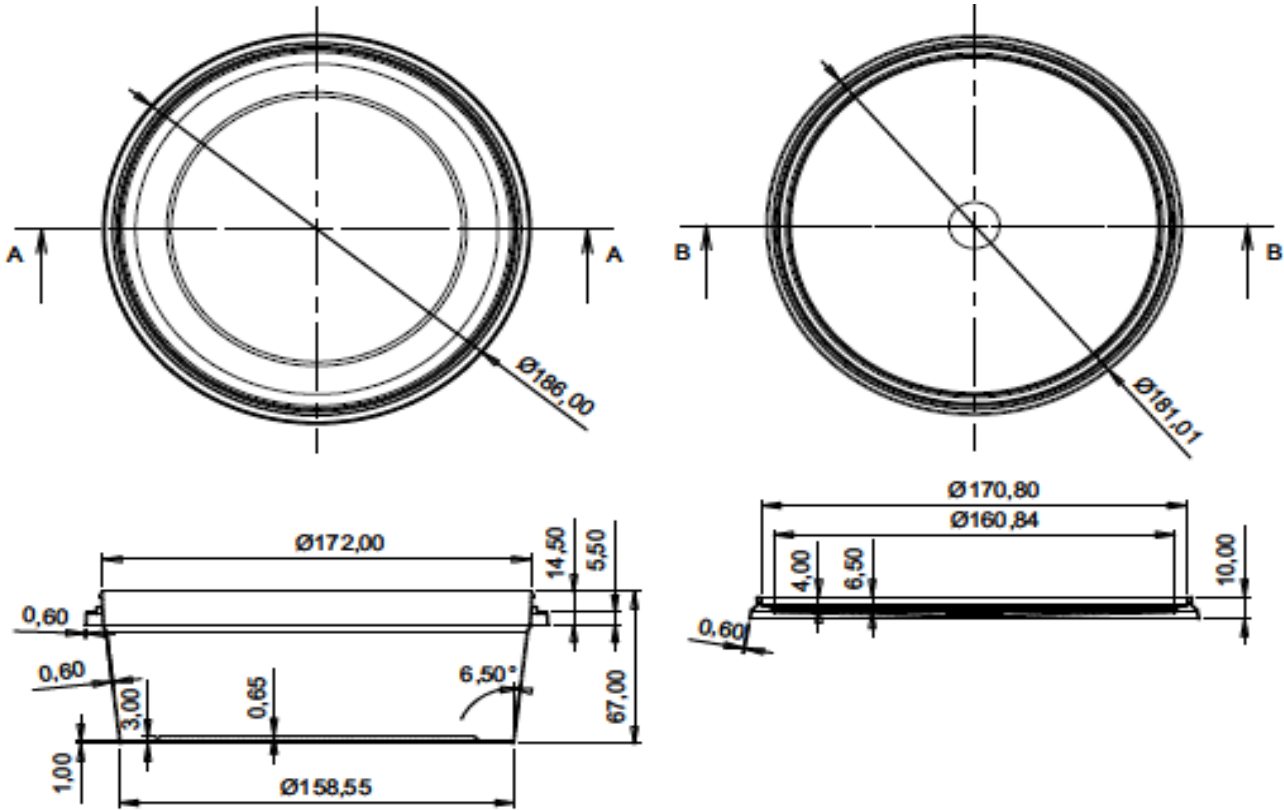

MATERIAL, COLOR, QUALITY CONTROL and WEIGHT

Containers and lids are produced by polypropylene in grades approved for food packaging according to New Code for Foodstuff and beverages 1998, Chapter II, Art.26.

Both lid and the container are food grade for human consumption.

DYK1005 container and lid can be produced with all colors as per the demand of the customer.

Production is certificated according to EN ISO 9001:2000.

Container: 37 gr (±%5) Lid: 19 gr (±%5) Volume: 1000 ml

100%
Recyclable
PP Material



LOGISTIC & PALLETISING

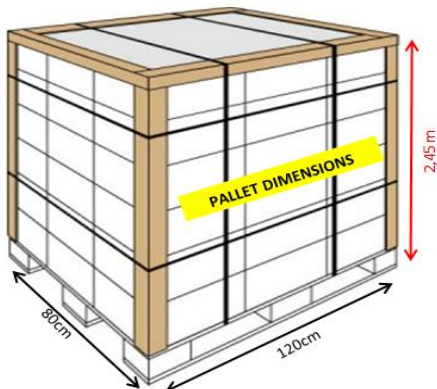

Box Dimensions	:	80*120*115 cm	(w * l * h)
Quantity per Box	:	1.392 pieces	(Set)
Quantity per Pallet	:	2.784 pieces	(Set)
Quantity per Truck	:	91.872 sets	
Quantity per 40'HC Container	:	66.816 sets	
Quantity per 20'DC Container	:	30.624 sets	

