

# PRODUCT DATA SHEET

PRODUCT CODE: DYF501

DESCRIPTION: PP-IML Container for Food Packaging



## TECHNICAL DRAWINGS & PICTURES

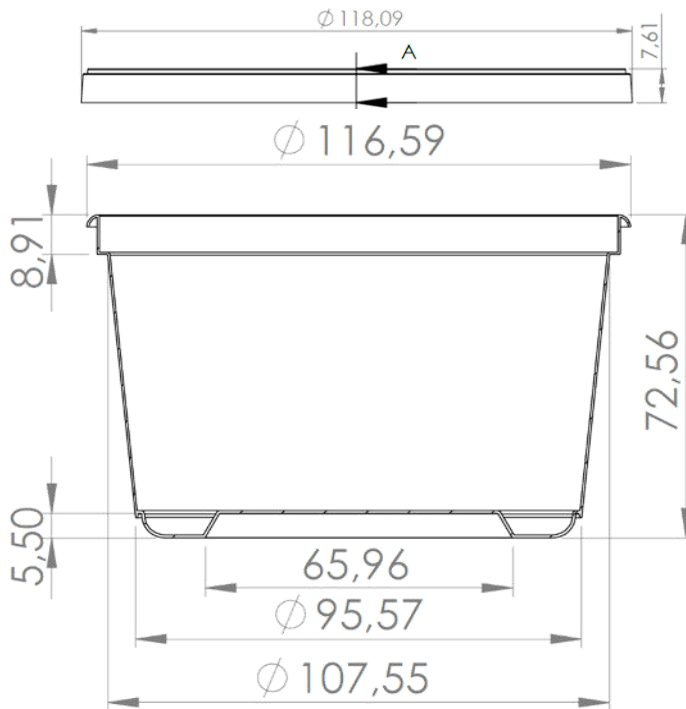

## MATERIAL, COLOR, QUALITY CONTROL and WEIGHT

Containers and lids are produced by polypropylene in grades approved for food packaging according to New Code for Foodstuff and beverages 1998, Chapter II, Art.26.

Both lid and the container are food grade for human consumption.

DYF501 container and lid can be produced with all colors as per the demand of the customer.

Production is certificated according to EN ISO 9001:2000.

Container: 15,8gr (±5%)

Lid:9,8gr (±5%)

Volume: 500 ml

100%  
Recyclable  
PP Material



## LOGISTIC & PALLETISING

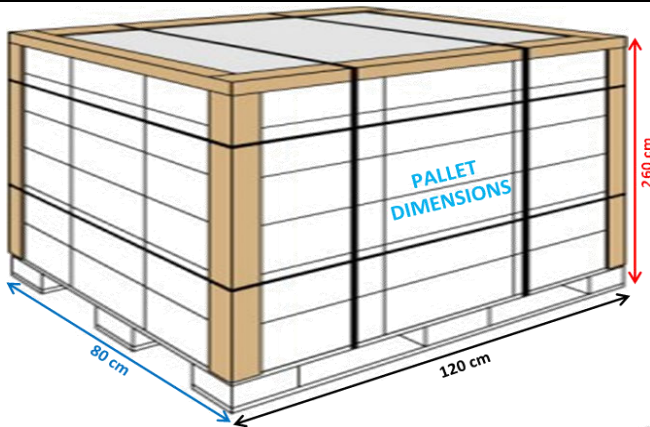

Body Carton Box Dimensions : 395\*795\*450

Quantity / Carton Box : 800pcs

*buckets and lids are packed in the same carton box*

*1 carton box includes 800pcs of buckets and 800pcs of lids*

Carton Boxes / Pallet : 15pcs

Quantity / Pallet : **12000pcs**

Quantity / Standart Truck : 396000 pcs

Quantity / 20'DC Container : 132000 pcs

Quantity / 40'HC Container : 288000 pcs

