

PRODUCT DATA SHEET

PRODUCT CODE: DYF440

DESCRIPTION: PP-IML Container for Food Packaging



TECHNICAL DRAWINGS & PICTURES

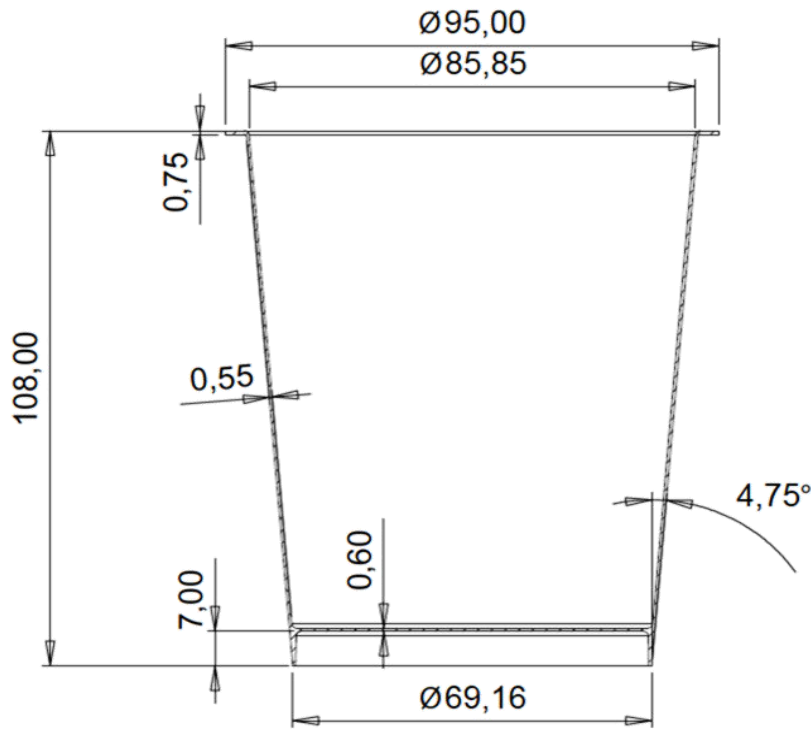

MATERIAL, COLOR, QUALITY CONTROL and WEIGHT

Containers and lids are produced by polypropylene in grades approved for food packaging according to New Code for Foodstuff and beverages 1998, Chapter II, Art.26.

Both lid and the container are food grade for human consumption.

**100%
Recyclable
PP Material**



DYF440 container and lid can be produced with all colors as per the demand of the customer.

Production is certificated according to EN ISO 9001:2000.

Container: 16,8gr (±5%)

Volume: 440 ml



LOGISTIC & PALLETISING

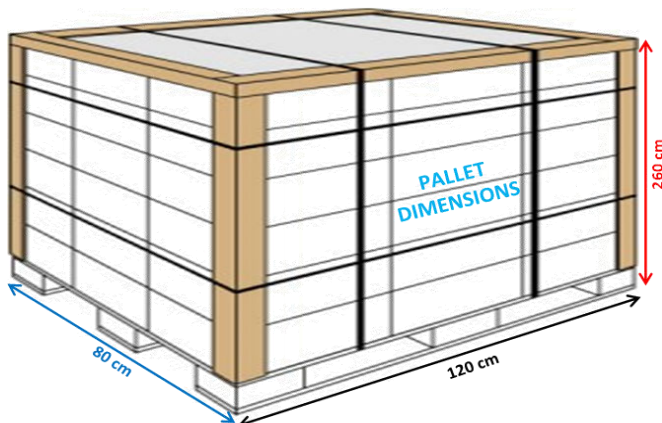

Body Carton Box Dimensions : 395*795*450
Quantity / Carton Box : 1000pcs

Carton Boxes / Pallet : 15 pcs
Quantity / Pallet : **15000 pcs**
Quantity / Standart Truck : 495000 pcs
Quantity / 20'DC Container : 165000 pcs
Quantity / 40'HC Container : 360000 pcs

