

PRODUCT DATA SHEET

PRODUCT CODE: DYF2500

DESCRIPTION: PP-IML Container for Food Packaging



TECHNICAL DRAWINGS & PICTURES & IML DIE CUT DRAWINGS

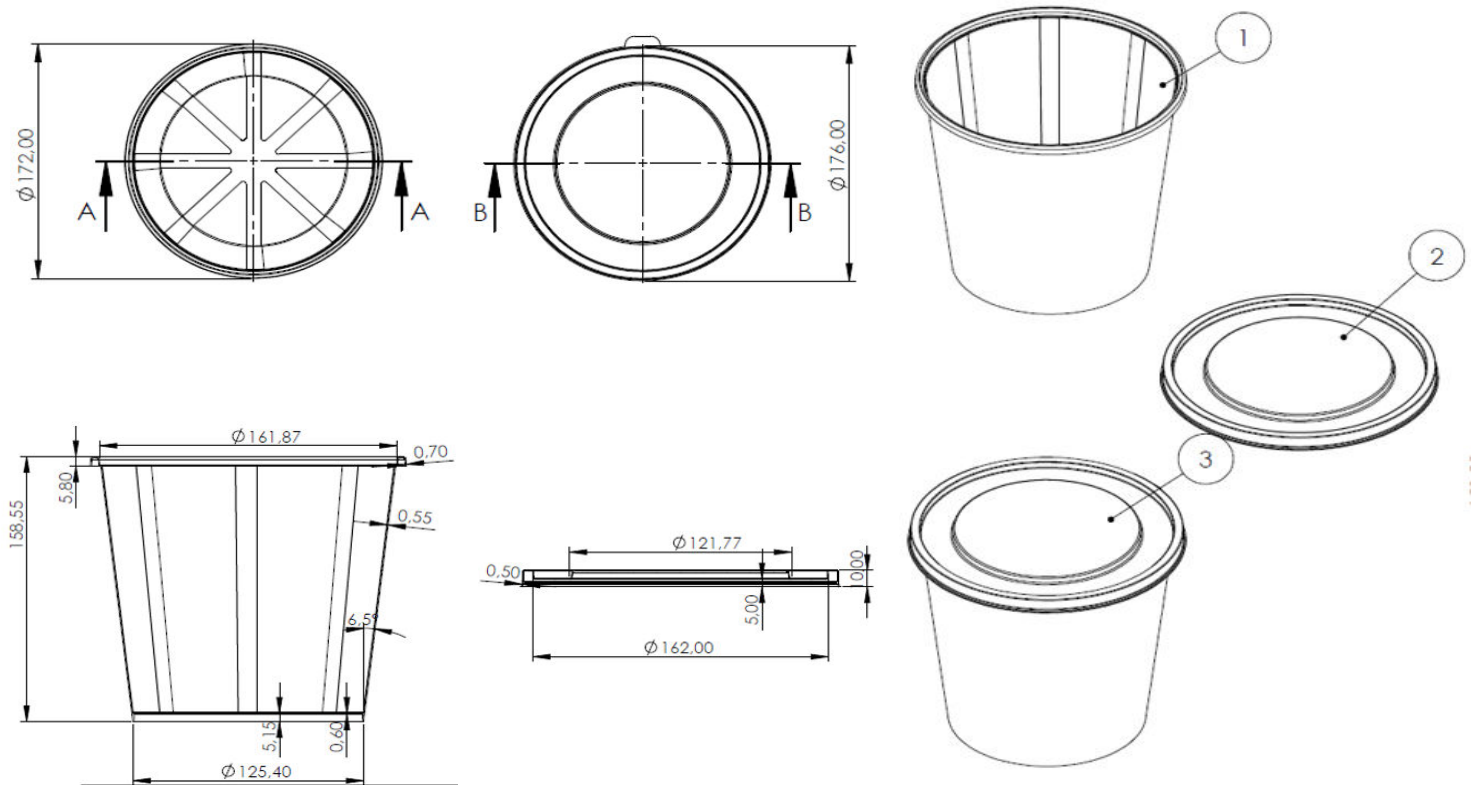

MATERIAL, COLOR, QUALITY CONTROL and WEIGHT

Containers and lids are produced by polypropylene in grades approved for food packaging according to New Code for Foodstuff and beverages 1998, Chapter II, Art.26.

Both lid and the container are food grade for human consumption.

DYF2500 container and lid can be produced with all colors as per the demand of the customer.

Production is certificated according to EN ISO 9001:2000.

Container: 42 gr (±%5) Lid: 16 gr (±%5) Brimful Volume: 2485 ml Filling Volume: 2380 ml

100%
Recyclable
PP Material



LOGISTIC & PALLETISING

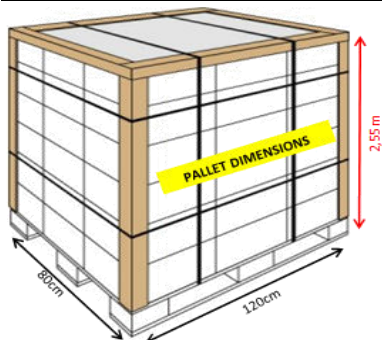

Box Dimensions	:	40*60*48 cm	(w * l * h)
Boxes per Pallet	:	20	
Quantity per Pallet	:	3.200 pieces (sets)	
Quantity per Truck	:	105.600 sets	
Quantity per 40'HC Container	:	80.000 sets	
Quantity per 20'DC Container	:	35.200 sets	

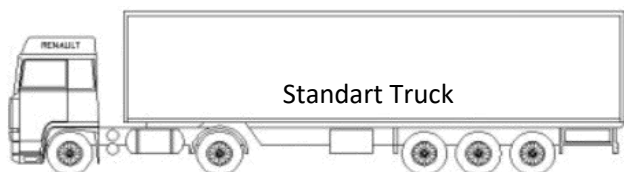

Standart Truck



20'DC

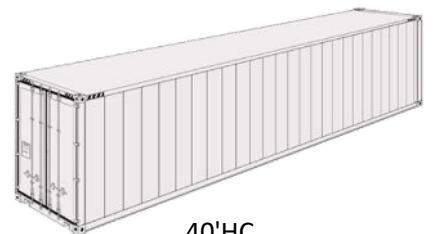

40'HC