

# PRODUCT DATA SHEET

PRODUCT CODE: DYF202

DESCRIPTION: PP-IML Cup for Food Packaging



## TECHNICAL DRAWINGS & PICTURES

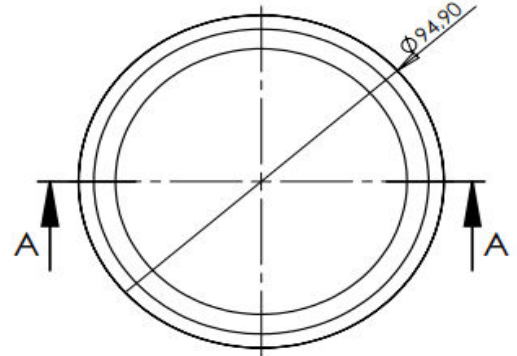
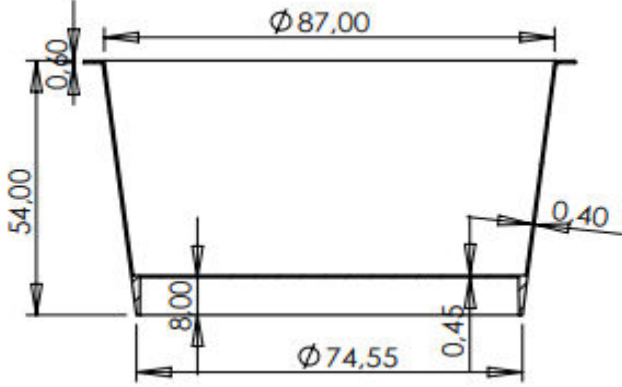

## MATERIAL, COLOR, QUALITY CONTROL and WEIGHT

Tubs and lids are produced by polypropylene in grades approved for food packaging according to New Code for Foodstuff and beverages 1998, Chapter II, Art.26.

Both lid and tube are food grade for human consumption.

DYF202 tub and lid can be produced with all colors as per the demand of the customer.

Production is certificated according to EN ISO 9001:2000.

Tub: 8,7 gr (±5%),

Lid: 5,3 gr (±5%)

Volume: 200 ml

100%  
Recyclable  
PP Material

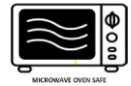

## LOGISTIC & PALLETISING

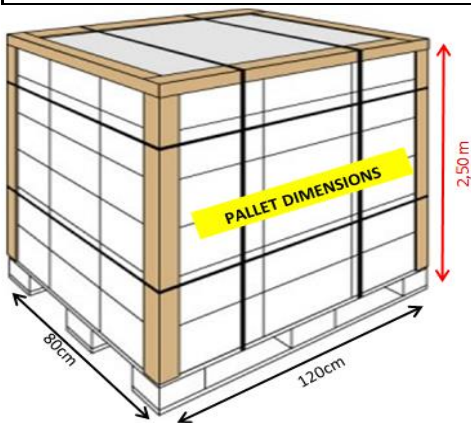

Box Dimensions	: 40*60*47 cm	(w * l * h)
Pieces per box (set)	: 840	
Boxes per Pallet (set)	: 20	
Quantity per Pallet	: 16.800 sets	
Quantity per Truck	: 554.400 sets	
Quantity per 40'HC Container	: 420.000 sets	
Quantity per 20'DC Container	: 184.800 sets	

