

PRODUCT DATA SHEET

PRODUCT CODE: DYF120

DESCRIPTION: PP-IML Container for Food Packaging



TECHNICAL DRAWINGS & PICTURES & IML DIE CUT DRAWINGS

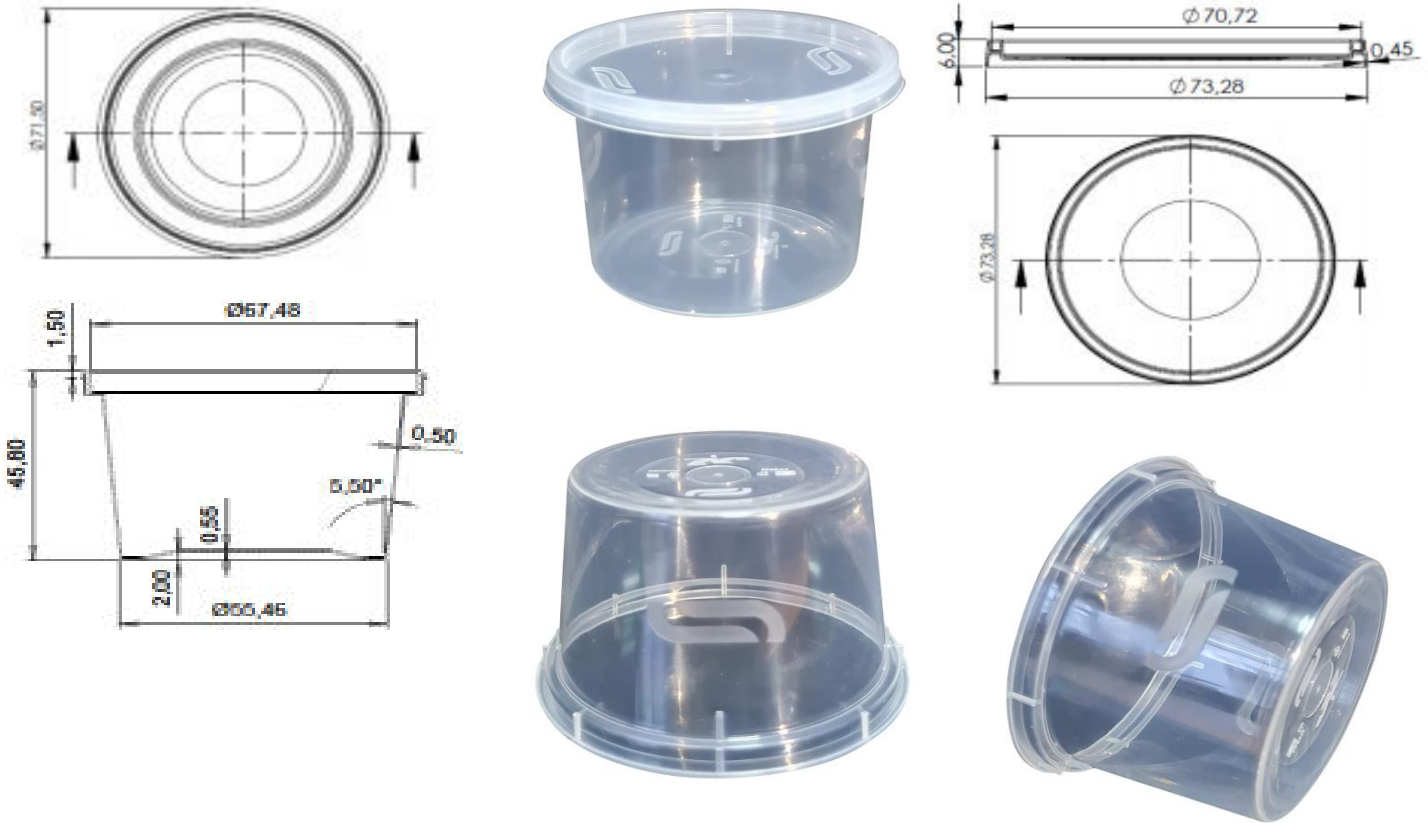

MATERIAL, COLOR, QUALITY CONTROL and WEIGHT

Containers and lids are produced by polypropylene in grades approved for food packaging according to New Code for Foodstuff and beverages 1998, Chapter II, Art.26.

Both lid and the container are food grade for human consumption.

100%
Recyclable
PP Material



DYF120 container and lid can be produced with all colors as per the demand of the customer.

Production is certificated according to EN ISO 9001:2000.

Container: 5,5 gr (±5%) Lid: 2,5 gr (±5%) Brimful Volume: 120 ml Filling Volume: 100 ml



LOGISTIC & PALLETISING

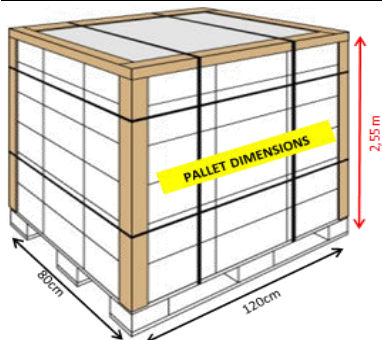

Box Dimensions	:	40*60*48 cm	(w * l * h)
Boxes per Pallet	:	20	
Quantity per Pallet	:	56.940 pieces	(Tub)
Quantity per Pallet	:	89.700 pieces	(Lid)
Quantity per Truck	:	1.201.200 sets	(Set = Body + Lid)
Quantity per 40'HC Container	:	910.000 sets	(Set = Body + Lid)
Quantity per 20'DC Container	:	320.320 sets	(Set = Body + Lid)

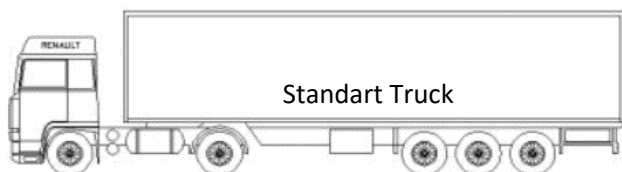

Standart Truck



20'DC

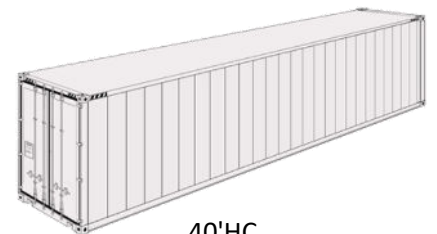

40'HC