

PRODUCT DATA SHEET

PRODUCT CODE: DÖK780

DESCRIPTION: PP-IML Container for Food Packaging



TECHNICAL DRAWINGS & PICTURES

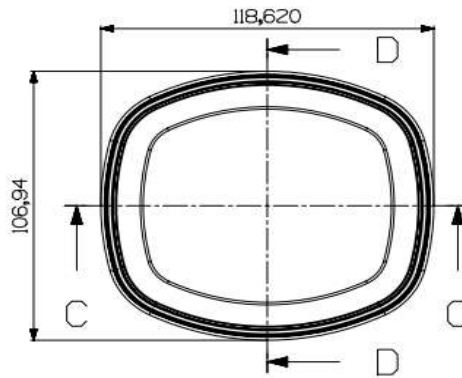
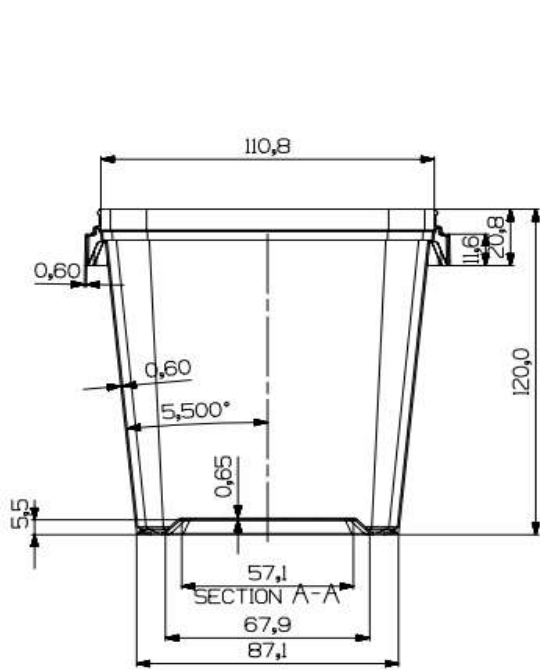

MATERIAL, COLOR, QUALITY CONTROL and WEIGHT

Containers and lids are produced by polypropylene in grades approved for food packaging according to New Code for Foodstuff and beverages 1998, Chapter II, Art.26. Both lid and the container are food grade for human consumption.



DÖK780 container and lid can be produced with all colors as per the demand of the customer.

Production is certificated according to EN ISO 9001:2000.

Container: 28,5 gr (±5%)

Lid: 8,5 gr (±5%)

Volume: 780 ml



LOGISTIC & PALLETISING

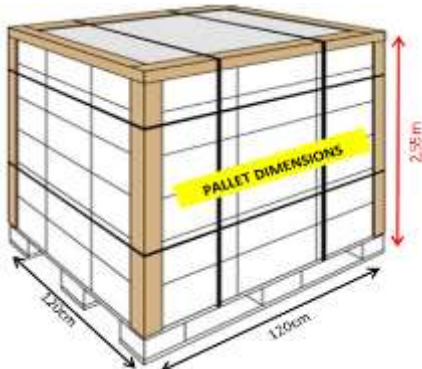

Box Dimensions	:	43*55*60 cm
Boxes per Pallet	:	20
Quantity per Box	:	600 pieces (Body)
Quantity per Box	:	2.400 pieces (Lid)
Quantity per Pallet	:	9.600 pieces (sets)
Quantity per Truck	:	211.200 sets
Quantity per 40'HC Container	:	420.000 sets
Quantity per 20'DC Container	:	184.800 sets

