

# PRODUCT DATA SHEET

PRODUCT CODE: DÖK700

DESCRIPTION: PP-IML Container for Food Packaging



## TECHNICAL DRAWINGS & PICTURES

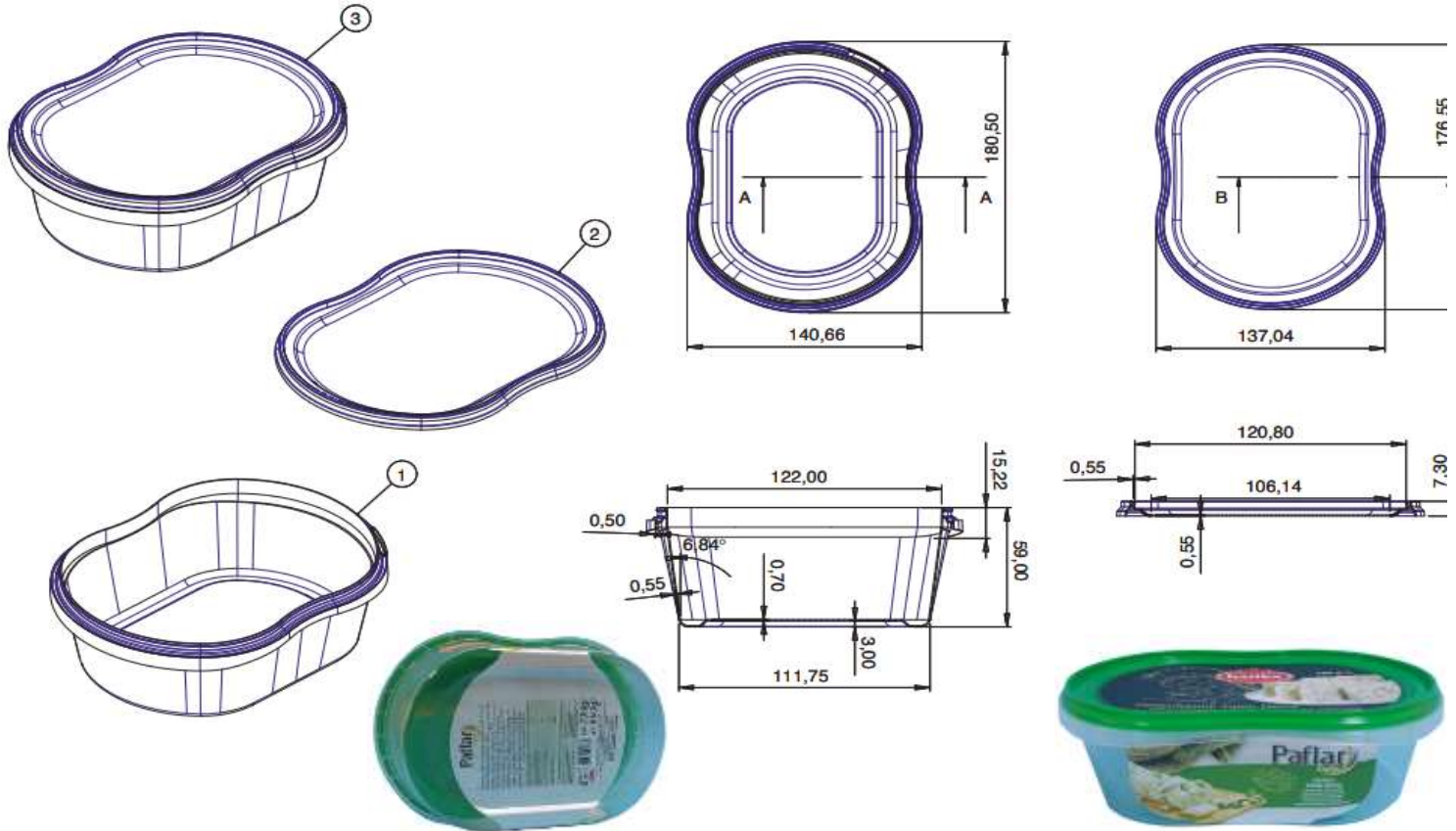

## MATERIAL, COLOR, QUALITY CONTROL and WEIGHT

Containers and lids are produced by polypropylene in grades approved for food packaging according to New Code for Foodstuff and beverages 1998, Chapter II, Art.26. Both lid and the container are food grade for human consumption.



DÖK700 container and lid can be produced with all colors as per the demand of the customer.

Production is certificated according to EN ISO 9001:2000.

Container: 29 gr (±1)

Lid: 14 gr (±1)

Volume: 700 ml



## LOGISTIC & PALLETISING

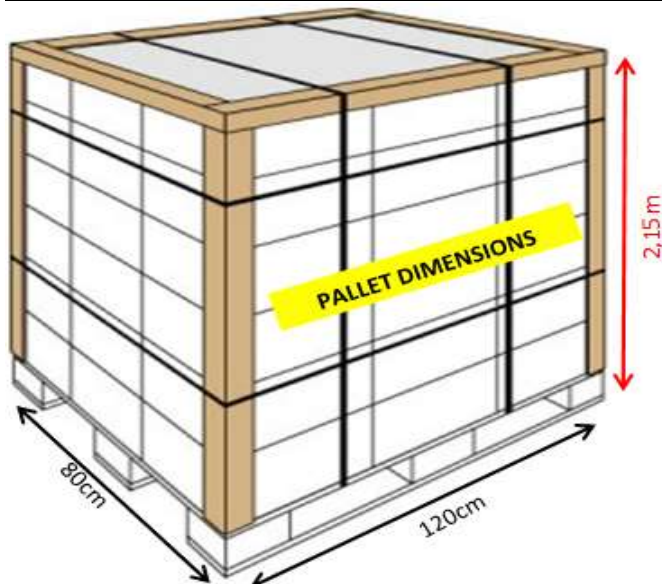

Pallet Dimension	: 80 x 120 cm
Box Dimensions	: 40*60*40 cm
Boxes per Pallet	: 20
Quantity per Pallet	: 3.420 pieces (Body)
Quantity per Pallet	: 10.880 pieces (Lid)
Pallets per Truck	: 33
Quantity per Truck	: 85.952 sets (Set = Body + Lid)

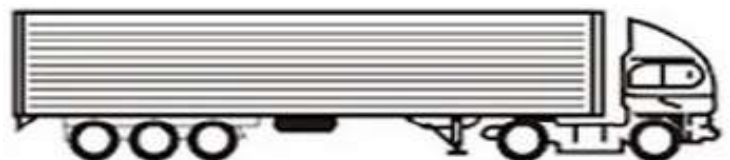

Quantity per Box	: 350 pieces (Body)
Quantity per Box	: 1400 pieces (Lid)

