

PRODUCT DATA SHEET

PRODUCT CODE: DKK851

DESCRIPTION: PP-IML Container for Food Packaging



TECHNICAL DRAWINGS & PICTURES

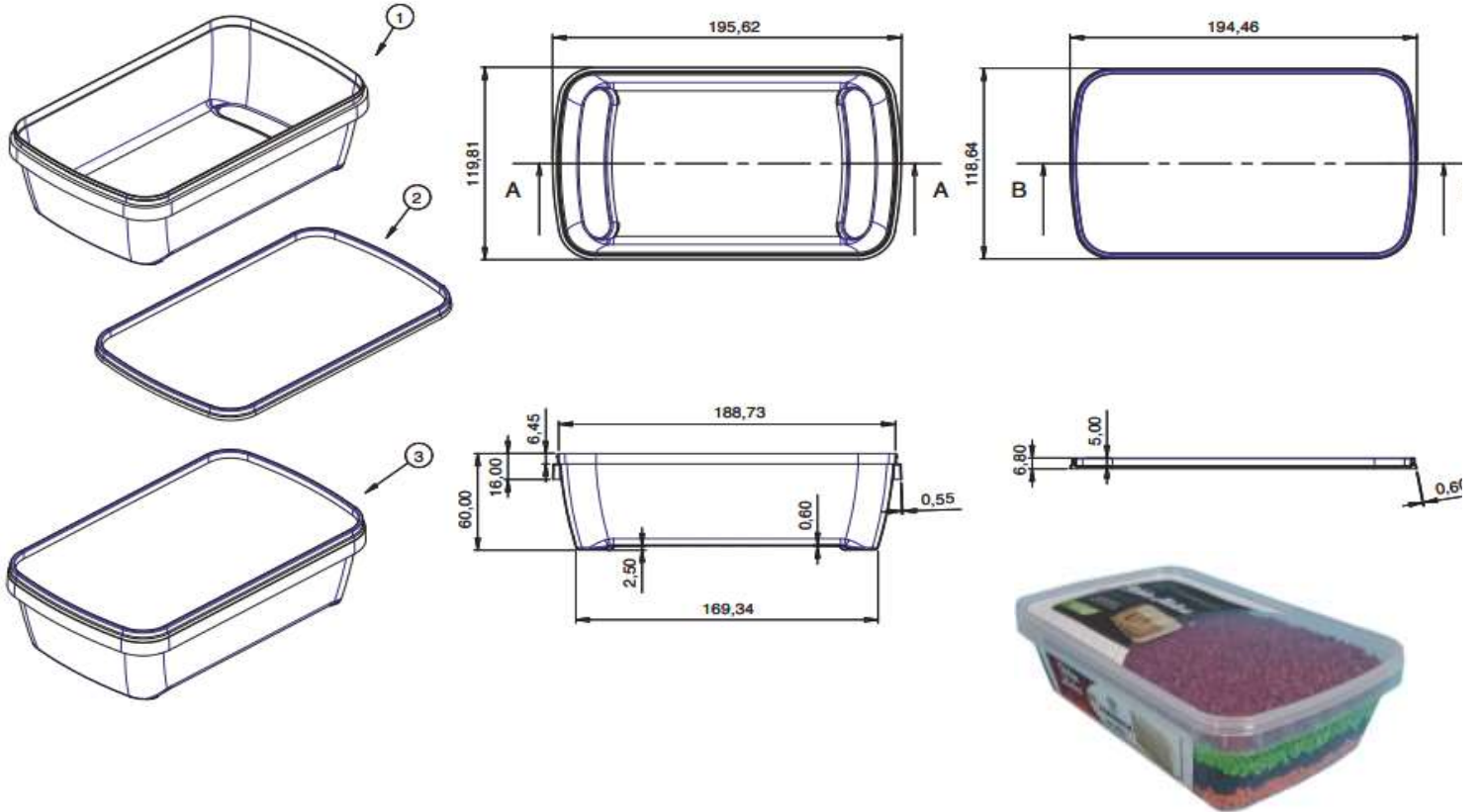

MATERIAL, COLOR, QUALITY CONTROL and WEIGHT

Containers and lids are produced by polypropylene in grades approved for food packaging according to New Code for Foodstuff and beverages 1998, Chapter II, Art.26. Both lid and the container are food grade for human consumption.



DKK851 container and lid can be produced with all colors as per the demand of the customer.

Production is certificated according to EN ISO 9001:2000.

Container: 32 gr (±1)

Lid: 16 gr (±1)

Volume: 850 ml



LOGISTIC & PALLETISING

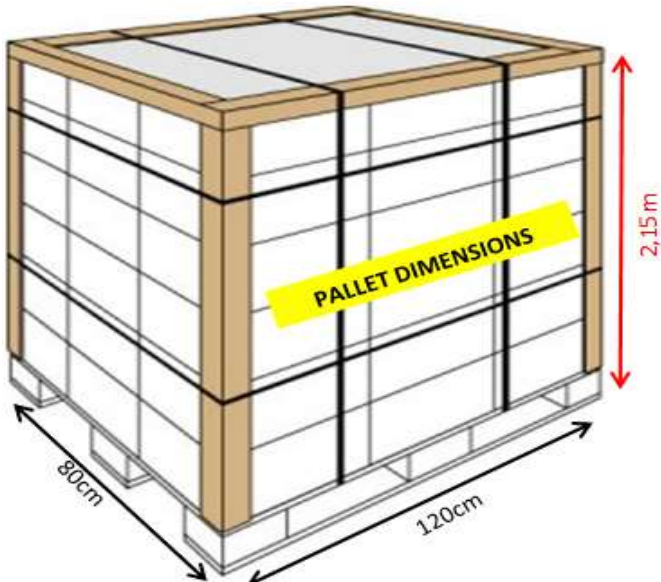

Pallet Dimension	: 80 x 120 cm
Box Dimensions	: 40*60*40 cm
Boxes per Pallet	: 20
Quantity per Pallet	: 3.420 pieces (Body)
Quantity per Pallet	: 10.880 pieces (Lid)
Pallets per Truck	: 33
Quantity per Truck	: 85.952 sets (Set = Body + Lid)

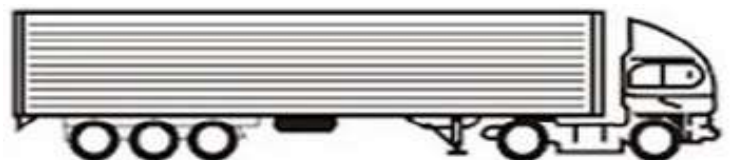

Quantity per Box	: 600 pieces (Body)
Quantity per Box	: 1200 pieces (Lid)

1

g

...

□

-
B

o

□

o

o

□