

# PRODUCT DATA SHEET

PRODUCT CODE: DKK610

DESCRIPTION: PP-IML Container for Food Packaging



## TECHNICAL DRAWINGS & PICTURES

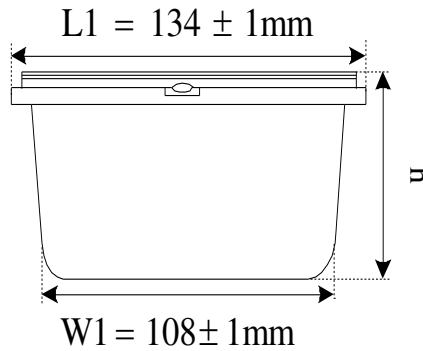
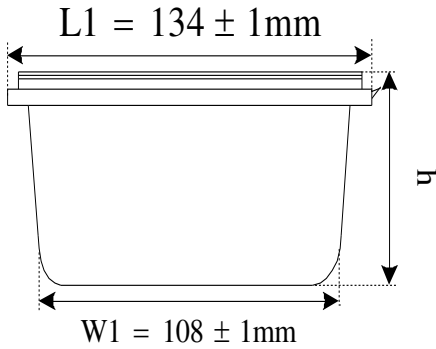

HEIGHT: 8.9 ± 1 mm

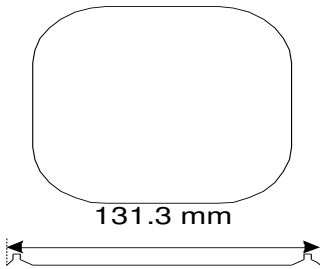

## MATERIAL, COLOR, QUALITY CONTROL and WEIGHT

Containers and lids are produced by polypropylene in grades approved for food packaging according to New Code for Foodstuff and beverages 1998, Chapter II, Art.26.

Both lid and the container are food grade for human consumption.

DKK610 container and lid can be produced with all colors as per the demand of the customer.

Production is certificated according to EN ISO 9001:2000.

Container: 27,5 gr (±5%)      Lid:14,5 gr (±5%)      Volume: 600 ml

100%  
Recyclable  
PP Material



## LOGISTIC & PALLETISING

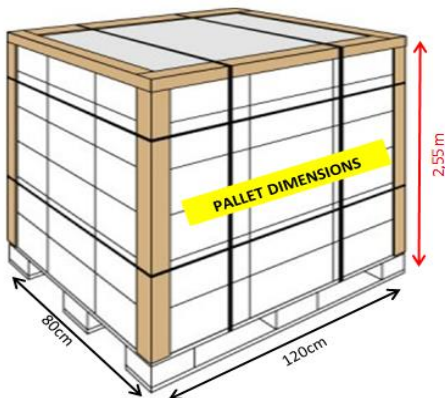

Box Dimensions	:	59*39*38 cm	(w * l * h)
Pallet Dimensions	:	80*120*255 cm	(w * l * h)
Quantity per Truck	:	134.100 sets	
Quantity per 40'HC Container	:	101.600 sets	
Quantity per 20'DC Container	:	44.700 sets	

