

PRODUCT DATA SHEET

PRODUCT CODE: DKK18000

DESCRIPTION: PP-IML Container for Food Packaging



TECHNICAL DRAWINGS & PICTURES & IML DIE CUT DRAWINGS

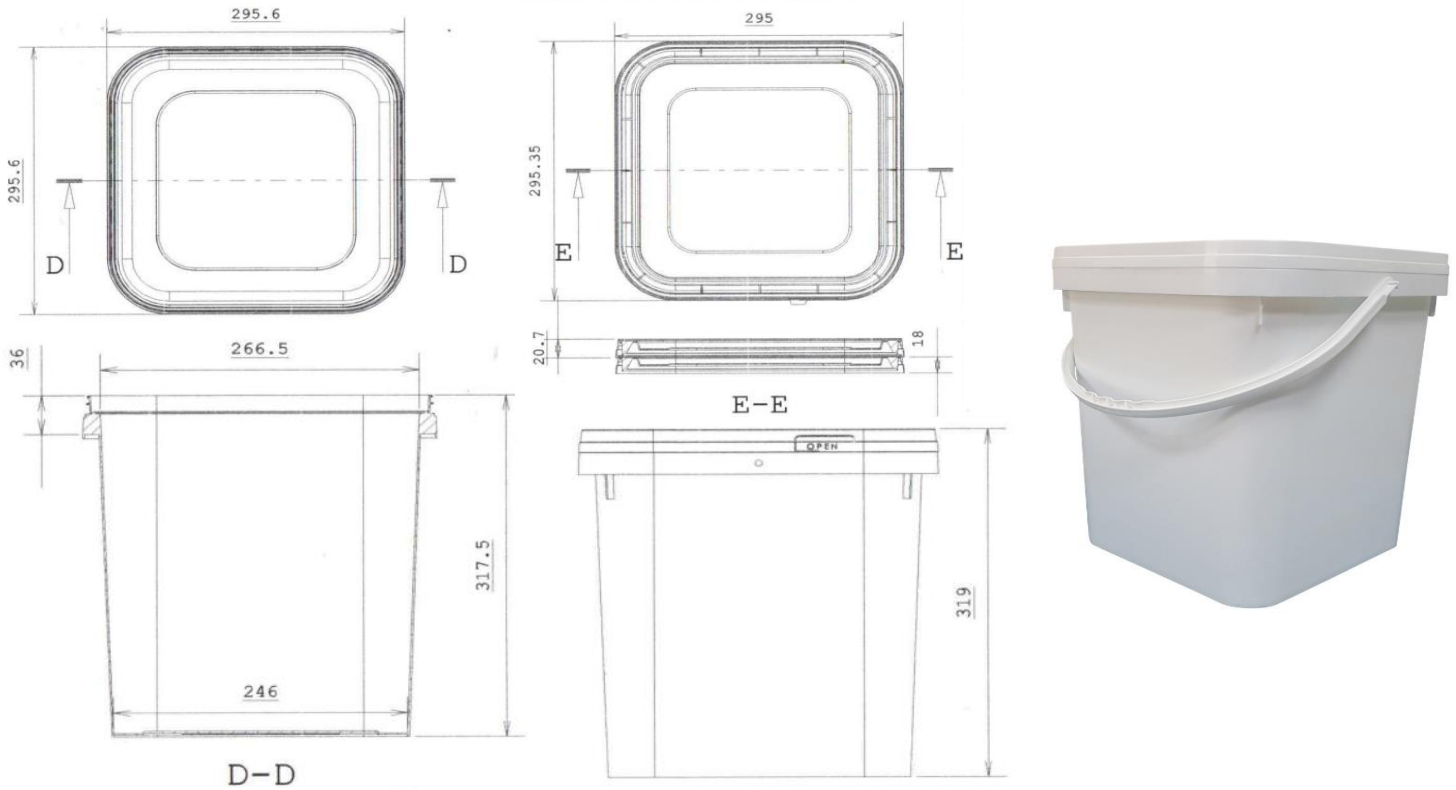

MATERIAL, COLOR, QUALITY CONTROL and WEIGHT

Containers and lids are produced by polypropylene in grades approved for food packaging according to New Code for Foodstuff and beverages 1998, Chapter II, Art.26. Both lid and the container are food grade for human consumption.



DKK18000 container and lid can be produced with all colors as per the demand of the customer. Production is certificated according to EN ISO 9001:2000.

Container: 515 gr (±5%) Lid: 147 gr (±5%) Volume: 18000 ml



LOGISTIC & PALLETISING

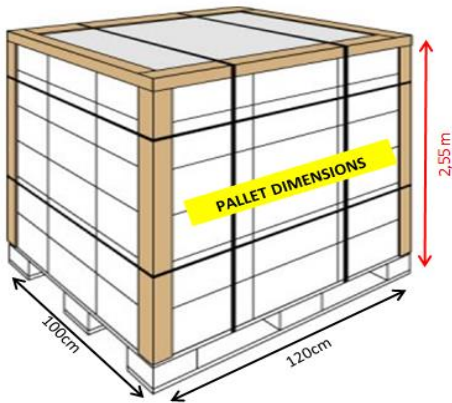

Quantity per Pallet	:	480 pieces	(Bucket)
Quantity per Pallet	:	1.800 pieces	(Lid)
Quantity per Truck	:	9.820 sets	
Quantity per 40'HC Container	:	7.930 sets	
Quantity per 20'DC Container	:	3.780 sets	

