

PRODUCT DATA SHEET

PRODUCT CODE: D400

DESCRIPTION: PP-IML Container for Food Packaging



TECHNICAL DRAWINGS & PICTURES

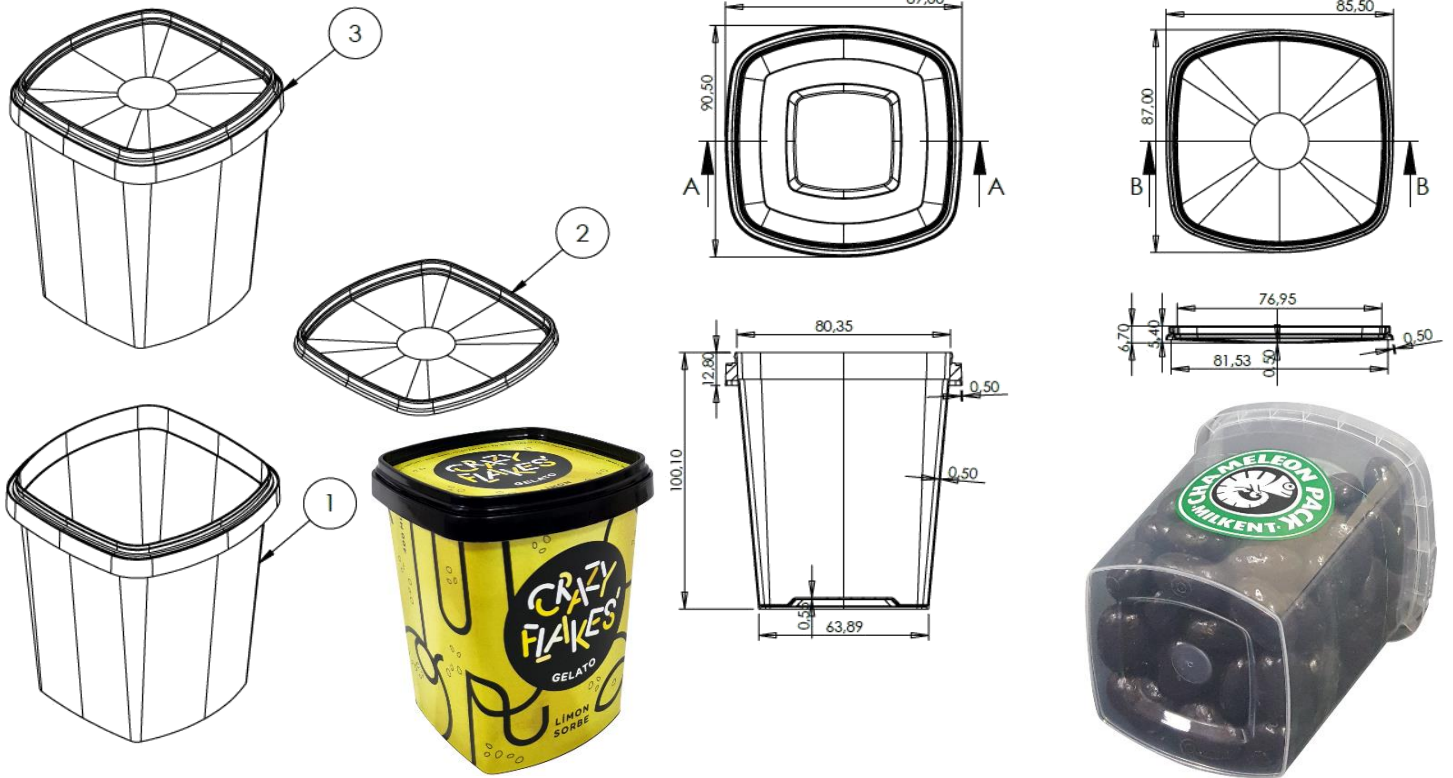

MATERIAL, COLOR, QUALITY CONTROL and WEIGHT

Containers and lids are produced by polypropylene in grades approved for food packaging according to New Code for Foodstuff and beverages 1998, Chapter II, Art.26.

Both lid and the container are food grade for human consumption.

D400 container and lid can be produced with all colors as per the demand of the customer.

Production is certificated according to EN ISO 9001:2000.

Container: 16,9 gr (±1)

Lid: 4,5 gr (±0,5)

Volume: 400 ml

**100%
Recyclable
PP Material**

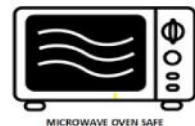

LOGISTIC & PALLETISING

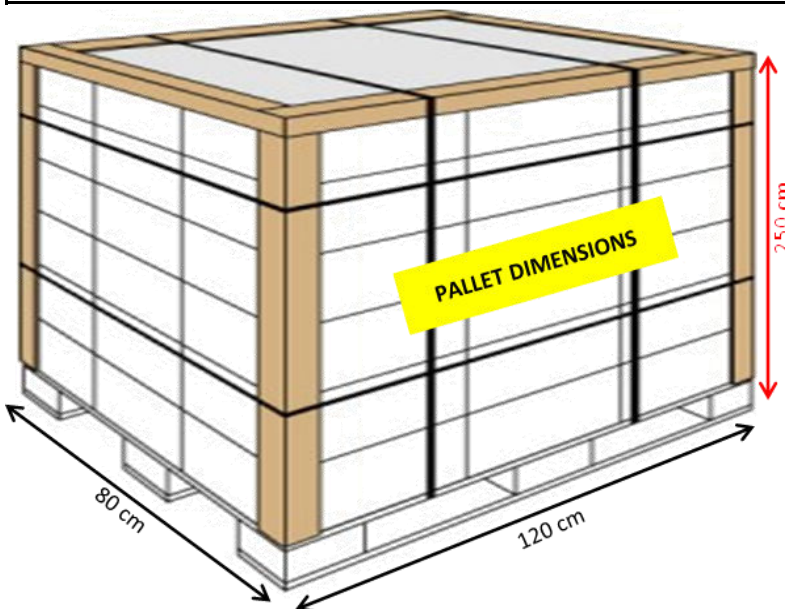

Box Dimensions (w*l*h) : 40*60*47 cm

Quantity / Box : 660 sets

660 pieces of tubs + 660 pieces of lids packed in the same box.

Boxes / Pallet : 20 pcs

Quantity / Pallet : 13.200 pcs

Quantity / Standard Truck : 435.600 pcs

Quantity / 20'DC Container : 145.200 pcs

Quantity / 40'HC Container : 330.000 pcs



20'DC

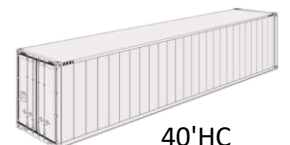

40'HC